

**8, heat pump, 9 kg,
White
WTX87MH0TH**



AutoClean SmartDry

- **AutoClean** :
- **SmartDry:**
- **AutoDry:**
- **Anti-Vibration**
- **ComfortControl:**

Built-in / Free-standing:
 :
 :
 / : White
 : 145.0 .
 : 842x598x613 mm
 : 54.2 .
 : 112 l

Fluorinated greenhouse gases:
 Hermetically sealed equipment:
 : 800 W
 () : 10 A
 : 220-240 V
 : 50 Hz

Drying process: automatic
 - (2010/30/EC): 9.0 .
 : A++: very efficient

Üzemkész állapot időtartama:30
 Condenser: A



- WMZ20600 :
 WTZ11400 :
 WTZPW20D Platform with pull-out
 WZ11410 Stacking Kit white

¹ Energy consumption kWh per year, based on 160 drying cycles of the standard cotton programme at full and partial load, and the consumption of the low power modes

**8, heat pump, 9 kg,
White
WTX87MH0TH**

AutoClean SmartDry

- 9 kg .
- (x x): 84.2 x 59.8 x 61.3 .
- 39., 170
- : 64

- Cottons, Synthetics, Mix, Delicates, Wool Finish, Timed Program
Warm, Smart Dry, AllergyPlus, Super Quick 40min, Towels,
Sportswear, Down Wear, Duvet, Shirts/Blouses

- Home Connect: , SmartDry
Wifi
- SelfCleaning Condenser Condenser

- Sensitive Drying system
-
- 120 120
- : Low heat, less ironing, programme length,
start/pause, fine-tuning of drying aim, 24h end time delay
- Anti-Vibration

- LED , ,
-

-
- Duo-Tronic

8, **heat pump, 9 kg,**
White
WTX87MH0TH

Measurements in mm

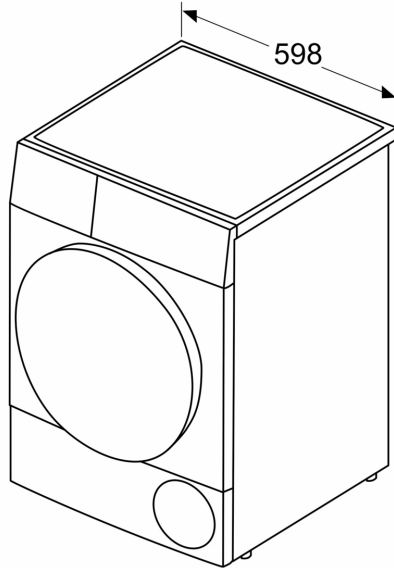

Measurements in mm

