

6, heat pump, 9 kg
WTR85T00TH



- WTZ1110 Condenser drainage kit
- WTZ11400 :
- WZ11410 Stacking Kit white

- **A+++**
- **AutoDry:**
- **SensitiveDrying:**
- **Anti-Vibration**
-
-

Built-in / Free-standing:

:

:

/ : White

: 145.0 .

worktop: 0 mm

: 842 x 598 x 613 mm

: 49.5 .

: 112 l

Fluorinated greenhouse gases:

Type of refrigerant: R290

Hermetically sealed equipment:

The quantity expressed in CO2 equivalent: 0.000

: 600 W

(): 10 A

: 220-240 V

: 50 Hz

Drying process: automatic

- (2010/30/EC): 9.0 .

: A++

Energy consumption electric dryer, full load - NEW (2010/30/EC) 2.08 kWh

Standard cotton programme time at full load: 225

Energy consumption electric dryer, partial load - NEW (2010/30/EC): 1.23 kWh

Standard cotton programme time at partial load: 137

Weighted annual energy consumption, electric dryer - NEW (2010/30/EC): 258.0 kWh/annum

Power consumption in off-mode - NEW (2010/30/EC): 0.10 W

Power consumption in left-on mode - NEW (2010/30/EC): 0.75 W

Weighted programme time: 175

Condensation efficiency class - NEW (2010/30/EC): B

Average condensation efficiency full load (%): 83 %

Average condensation efficiency partial load (%): 83 %

Weighted condensation efficiency for the standard cotton programme at full and partial load: 83 %



6, heat pump, 9 kg WTR85T00TH

- 9 kg .
- (x x): 84.2 x 59.8 x 61.3 .
- 39., 170
- 112
- : 64

- Cottons Cupboard Dry EXtra, Cottons Cupboard Dry, Cottons Iron Dry, Sportswear, Allergy+, Mix, Timed program warm, Timed Programme cold, Wool finish, Down, Super 40', Super 15', Easy Care Iron Dry, Easy Care Cupboard Dry, Easy Care Cupboard Dry Extra

- Sensitive Drying system
-
- 60 120
- : Low heat, less ironing, programme length, start/pause, fine-tuning of drying aim, 24h end time delay
- Anti-Vibration

- LED , ,
-

-
- Duo-Tronic

6, heat pump, 9 kg
WTR85T00TH

Measurements in mm

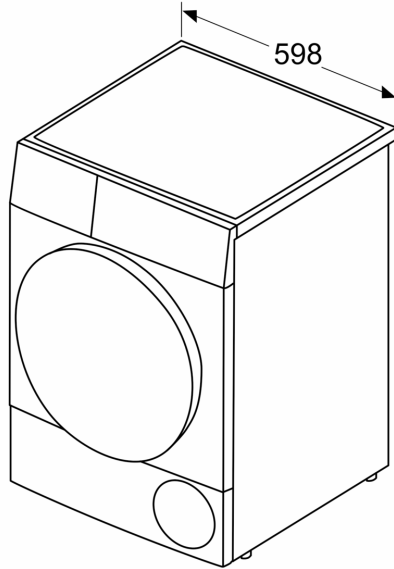

Measurements in mm

