

4, ,
WTN86205TH

9 kg

100%



- AutoDry:
- Duo-Tronic
- SensitiveDrying:
-

Built-in / Free-standing:

:

:

/ : White

: 145.0 .

: 842 x 598 x 613 mm

: 41.9 .

: 112 l

: 2600 W

() : 13 A

: 220-240 V

: 50 Hz

Drying process: automatic

- (2010/30/EC): 9.0 .

: B

Energy consumption electric dryer, full load - NEW (2010/30/EC) 5.20 kWh

Standard cotton programme time at full load: 149

Energy consumption electric dryer, partial load - NEW (2010/30/EC): 2.81 kWh

Standard cotton programme time at partial load: 84

Weighted annual energy consumption, electric dryer - NEW (2010/30/EC): 616.0 kWh/annum

Power consumption in off-mode - NEW (2010/30/EC): 0.10 W

Power consumption in left-on mode - NEW (2010/30/EC): 0.50 W

Weighted programme time: 112

Condenser: B

Average condensation efficiency full load (%): 88 %

Average condensation efficiency partial load (%): 88 %

Weighted condensation efficiency for the standard cotton programme at full and partial load: 88 %

-
- WTZ1110 Condenser drainage kit
 - WTZ11400 :
 - WTZ20410 Connection set
 - WTZPW20D Platform with pull-out



4, , 9 kg
WTN86205TH

100%

- 9 kg .
- (x x) 84.2 x 59.8 x 59.9 .
- 39., 175°
- : 65

- Cottons Cupboard Dry EXtra, Cottons Cupboard Dry, Cottons Iron Dry, Sportswear, AllergyPlus, Mix Load, Timed Program Warm, Timed Programme Cold, Wool Finish, Downs Clothes, Quick 40min, Shirt 15min, Synthetics Iron Dry, Synthetics Cupboard Dry, Synthetics Cupboard Dry Extra

- Anti-Vibration
- Sensitive Drying system
- 120
- : Low heat, less ironing, programme length, start/pause, fine-tuning of drying aim, 24h end time delay

- LED , ,
-

- Duo-Tronic

4, , 9 kg
WTN86205TH

Measurements in mm

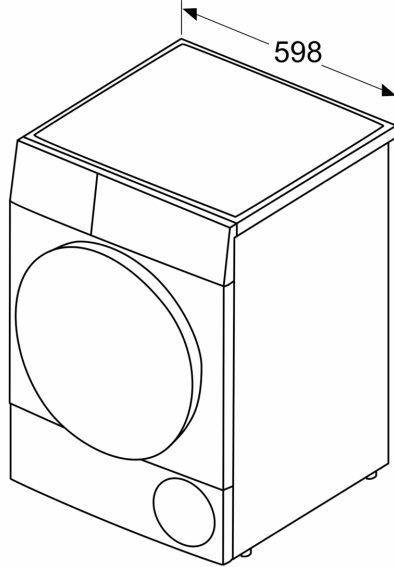

Measurements in mm

