

**Series 4, Side-by-Side Fridge, 178.7 x 90.8 cm, Stainless steel  
KAI93VI304**



**The NoFrost side-by-side fridge-freezer with integrated ice and water dispenser: saves you from defrosting and, moreover, refreshes you at the push of a button**

- **Intelligent Inverter Technology:** ensures stable temperature control and efficient performance.
- **A++ energy class refrigerator consumes 40% less energy than A energy class.**
- **Ice & Water Dispenser with Tank:** cubed or crushed ice and chilled water - anytime you need it.
- **Multi Airflow:** regularly circulates cool, fresh air to maintain an even temperature.
- **Cools new food placed inside faster, thus protecting already cooled food.**

---

Built-in / Free-standing: .....	Free-standing
Number of compressors: .....	1
Number of independent cooling systems: .....	1
Width of the appliance: .....	908 mm
Height: .....	1787 mm
Depth: .....	707 mm
Net weight: .....	104.6 kg
Required niche size for installation (HxWxD): .....	mm
Door panel options: .....	Not possible
Door hinge: .....	left and right
Number of Adjustable Shelves in fridge compartment: .....	0
Shelves for Bottles: .....	No
Frost free system: .....	Freezer
Interior ventilator: .....	No
Reversible Door Hinge: .....	No
Length electrical supply cord: .....	170 cm
Noise level: .....	42 dB(A) re 1pW
Connection rating: .....	W
Fuse protection: .....	10 A
Voltage: .....	220-240 V
Frequency: .....	50-60 Hz
Energy efficiency class: .....	A++
Energy consumption annual - NEW (2010/30/EC): .....	343.00 kWh/annum
Refrigerator Net capacity - NEW (2010/30/EC): .....	368 l
Freezer Net capacity - NEW (2010/30/EC): .....	165 l
Energy consumption: .....	kWh
Freezing capacity) - NEW (2010/30/EC): .....	13 kg/24h
Freezing capacity: .....	kg
Storage Period in Event of Power Failure (h): .....	8 h
Included accessories: .....	1 x connection hose, 1 x egg tray

---



## Series 4, Side-by-Side Fridge, 178.7 x 90.8 cm, Stainless steel KAI93VI304

**The NoFrost side-by-side fridge-freezer with integrated ice and water dispenser: saves you from defrosting and, moreover, refreshes you at the push of a button**

### Consumption

- Energy efficiency class: A++
- Energy efficiency class: A++ (343 kWh per year). Actual energy consumption will depend on how the appliance is used and where it is located.
- Total net capacity: 533 litres
- Noise level dB(A) re 1 pW: 42

### Design

- Doors inox EasyClean, side panels Grey
- vertical door handle
- Internal LED lights
- Interior with metal applications

### Comfort and Safety

- Frost free - never again defrosting
- Exterior digital display - at a glance perfectly under control
- Separate temperature control for cooling and freezing section
- Supercool function
- Superfreeze Function
- Optical and acoustic warning system

### Ice and Water

- Illuminated water and ice / crushed ice dispenser
- Automatic ice cube maker
- Watertank 4.5L, shelf integrated

### Fridge Section

- Net capacity refrigeration zone: 368 l
- Multi Airflow-System
- 2 door trays
- MultiBox - the special compartment in the door

### Freshness System

- 2 vegetable container on rails

### Freezer Section

- Net capacity freezer 165 l
- Freezing capacity: 13 kg in 24 hours
- Storage time in power failure: 8 Hours
- 2 transparent freezer drawers
- 3 safety glass trays there of 0 height adjustable

### TECHNICAL INFORMATION

- Appliance adjustable on 4 roles
- Climate Class SN-T

### APPLIANCE DIMENSION

- Dimensions: H 178.7 cm x L 90.8 cm x D 70.7 cm
- Rated Voltage 220 - 240 V

### Standard Accessories

- Ice cube tray, egg tray

### SPECIAL ACCESORIES

### Country Specific Options

- Gross capacity, total: 610 l
- Gross capacity cooling 386 l
- \*\*\*\* freezer 224 l (-18°C and below)
- Based on the results of the standard 25-hour test. Actual consumption depends on usage/position of the appliance.

### ENVIREMENT AND SAFETY

### INSTALLATION

### General Information

**Series 4, Side-by-Side Fridge, 178.7 x 90.8 cm, Stainless steel  
KAI93VI304**

Measurements in mm

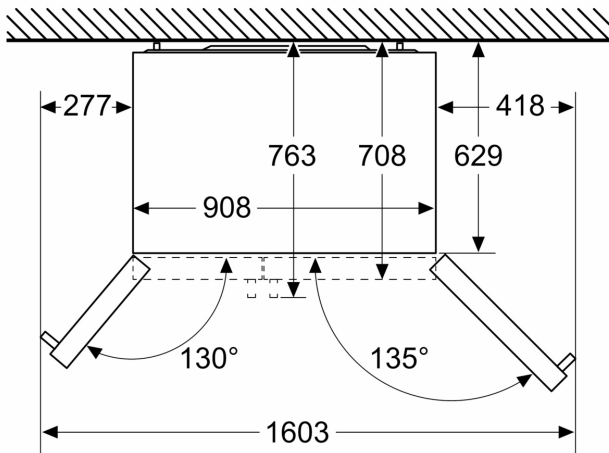

Measurements in mm

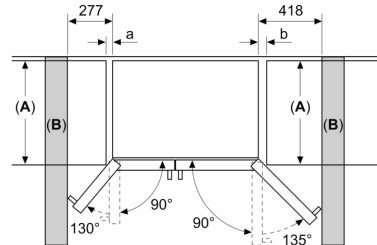

A	a	b
≤ 600	50	50
600 < A ≤ 650	50	50
650 < A ≤ 700	53	96
> 700	277	418

**A:** Kitchen cabinet or worktop depth

**B:** Wall  
Drawers can be pulled out with door open to 90°

Drawers can be taken out with door completely opened

measurements in mm

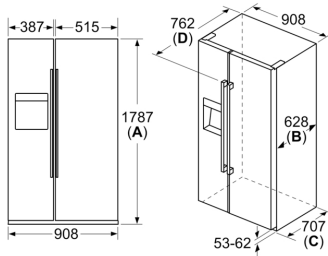

Specifications	
<b>A</b>	Front is adjustable from 1783 to 1792
<b>B</b>	Cabinet depth
<b>C</b>	Depth incl. door, without handle
<b>D</b>	Depth incl. door, with handle