

Series 2, Wall-mounted Extractor Hood, 60 cm, Stainless steel DWB66BC51Z



Box-design hood: performance and matching kitchen design bundled in one hood.

- **Metal Grease Filter:** cleans the air, captures grease, easy monthly clean-up.

Typology:Wall-mounted
 Length electrical supply cord: 130.0 cm
 Height of the chimney: 583-912/583-1022 mm
 Height of the appliance: 53 mm
 Minimum distance above an electric hob: 550 mm
 Minimum distance above a gas hob:650 mm
 Net weight:12.1 kg
 Type of control:mechanical
 Number of speed settings:3
 Max. air extraction: 621 m³/h
 Max. air recirculation: 422 m³/h
 Maximum Air flow: 621 m³/h
 Number of lights:2
 Noise level:69 dB(A) re 1pW
 Diameter of air outlet: 150 / 120 mm
 Grease filter material: Washable stainless steel
 EAN code:4242005059201
 Connection rating: 220 W
 Fuse protection:10 A
 Voltage: 220-240 V
 Frequency: 50; 60 Hz
 Plug type: South Africa plug
 Installation typology:Wall-mounted

DHZ1225	Chimney extension 1000 mm
DHZ1235	Chimney extension 1500 mm
DHZ6550	Brushed steel back panel
DHZ6551	Brushed steel back panel
DWZ0XX0J0	Long Life recirculation kit
DWZ1DX1B4	Clean Air Standard odor filter (repl.)
DWZ1DX1I4	Clean Air Standard recirculation kit
DWZ1DX1I6	Clean Air Plus recirculation kit
DWZ1FX5C6	Clean Air Plus recirc. kit external
DWZ1FX5D1	Long Life recirculation kit external
DZZ0XX0P0	Long Life odor filter (replacement)
DZZ1XX1B6	Clean Air Plus odor filter (replacement)



Series 2, Wall-mounted Extractor Hood, 60 cm, Stainless steel DWB66BC51Z

- Power rating: 220 W
- Electrical cable length 1.3 m

Box-design hood: performance and matching kitchen design bundled in one hood.

-
- Energy Efficiency Class: B*
 - Average Energy Consumption: 46.5 kWh/year*
 - Blower Efficiency Class: A*
 - Lighting Efficiency Class: A*
 - Grease Filtering Efficiency Class: B*
 - Noise max. Normal Level: 69 dB*

Operating and power:

- Chimney extractor hood
- Brushed steel
- 60 cm Brushed steel Chimney extractor hood with glass canopy
- 60 cm wide
- Suitable for ducted or recirculating operation
- Recirc. kit or clean air kit
- Designed for wall mounted installation
- push buttons for extractor speeds and light
- 3 speed operation via push buttons
- 3 speed operation
- Twin channel high performance fan motor
- 2 x 1,5W LED
- Light Intensity: 99 lux
- Colour Temperature: 3500 K
- Removable metal grease filters, dishwasher safe
- Ducted extraction rate according to DIN/EN 61591 max. 621 m³/h
- Maximum extraction 621 m³/h
- Noise level according to EN 60704-3 und EN 60704-2-13 at max. normal use exhaust air: 69 dB(A) re 1 pW (56 dB(A) re 20 μPa sound pressure)
- Diameter pipe Ø 150 mm (Ø 120 mm enclosed)
- Yes
- Max. extraction rate: 621 m³/h
- Extraction rate in recirculation mode:
- Max. normal use: 358 m³/h
- Noise level in recirculation mode:
- Max. normal use: 75 dB(A) re 1 pW (62 dB(A) re 20 μPa sound pressure)
- Dimensions exhaust air (HxWxD): 635-965 x 600 x 500 mm
- Dimensions recirculating (HxWxD): 635-1075 x 600 x 500 mm
- Dimensions recirculating with CleanAir module (HxWxD):
- 703 x 600 x 500mm - mounting with outer chimney
- 833-1163 x 600 x 500 mm - mounting with telescopic chimney
- Dimensions recirculating with cleanAir module (HxWxD);
- 703 x 600 x 500mm - mounting with outer chimney
- 833-1163 x 600 x 500 mm - mounting with telescopic chimney
- Dimensions recirculating with CleanAir module (HxWxD):
- 703 x 600 x 500mm - mounting with outer chimney
- 833-1163 x 600 x 500 mm - mounting with telescopic chimney

**Series 2, Wall-mounted Extractor
Hood, 60 cm, Stainless steel
DWB66BC51Z**

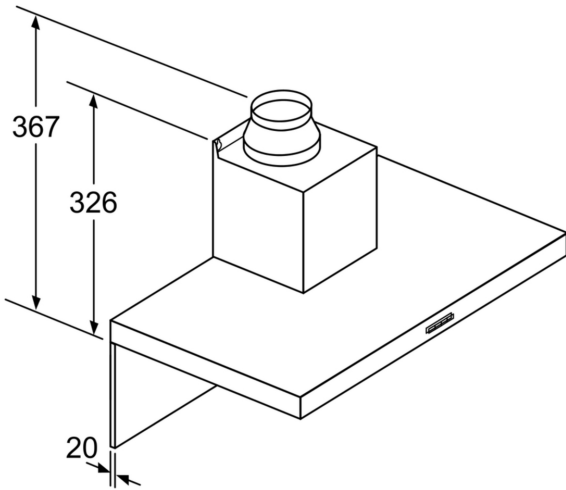

If a back panel is used, the design of the appliance must be considered. measurements in mm

Measurements in mm

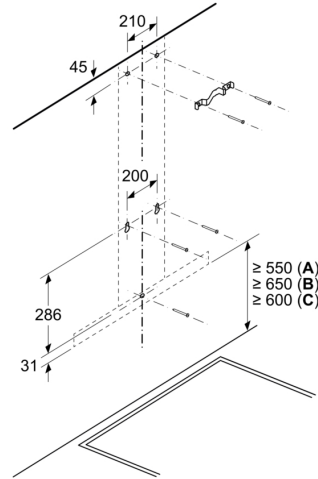

- A: Electric
- B: Gas - from upper edge of pan support
- C: Electric - for Australia and New Zealand

Measurements in mm

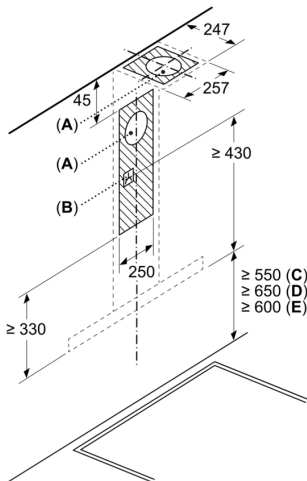

- A: Exhaust air outlet
- B: Socket
- C: Electric
- D: Gas - from upper edge of pan support
- E: Electric - for Australia and New Zealand

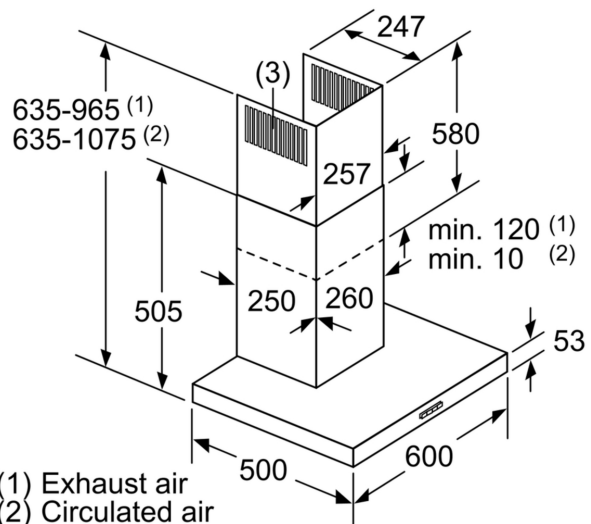

- (1) Exhaust air
 - (2) Circulated air
 - (3) Air outlet – slots for exhaust air to be mounted facing down
- measurements in mm