

Series 4, Built-in oven with added steam function, 60 x 60 cm, Stainless steel
HUA736ER0



- Grâce au plateau de cuisson Air Fry Grill, vous pouvez cuisiner des aliments plus sains en utilisant moins de matières grasses.
- **3D Hotair:** even heat distribution for perfect results on up to three levels.
- **AutoPilot 10:** every dish is a perfect success thanks to 10 pre-set automatic programmes.
- **Cleaning Assistance:** less cleaning effort
- **Hotair Gentle:** saves energy while baking and roasting.

Gross weight: 35.6 kg
 Built-in / Free-standing: Built-in
 Integrated Cleaning system: EcoClean Direct program, Hydrolytic
 Required niche size for installation (HxWxD): 585-595 x 560-568 x 550 mm
 Dimensions: 595x594x548 mm
 Dimensions of the packed product (HxWxD): 670x665x685 mm
 Control Panel Material: metal lacquered
 Door Material: Glass
 Net weight: 33.2 kg
 Usable volume of cavity: 76 l
 Heating modes:: Air fry, Full width grill, Hotair gentle, Hot Air, Conventional heat, Pizza setting, Bottom heat
 Length electrical supply cord: 120 cm
 Pull-out system: 1-level
 Included accessories: 1 x combination grid, 1 x universal pan, 1 x air fry & grill tray, 1 x deep tray
 Broil Element Wattages cavity 1: 2700 W
 Convection Element Wattages cavity 1: 2200 W
 Energy efficiency class: A
 Energy consumption per cycle conventional (2010/30/EC): 0.98 kWh/cycle
 Energy consumption per cycle forced air convection (2010/30/EC): 83 kWh/cycle
 Energy efficiency index (2010/30/EC): 95.4 %
 Connection rating: 3400 W
 Fuse protection: 16 A
 Voltage: 220-240 V
 Frequency: 50; 60 Hz
 Plug type: GARDY plug w/ earthing
 Energy input: Electric
 Required cutout/niche size for installation (in): x
 Dimensions of the packed product: 26.37 x 26.18 x 26.96
 Net weight: 73.000 lbs
 Gross weight: 78.000 lbs



Series 4, Built-in oven with added steam function, 60 x 60 cm, Stainless steel HUA736ER0

installation drawing”

Type of oven / heating system:

- Additional heating methods with steam: Steam 100%, Regeneration, fermentation, Defrost
- Temperature range 50 °C - 275 °C
- Cavity volume: 76 l

Hook-in racks / rails

- Number of shelf levels: 5 PC
- 1 level telescopic shelf

Design:

- Rotary Control
- Cavity inner surface: Stainless steel

Cleaning:

- Ecolyse features: back panel, ceiling, side liners
- EcoClean

Comfort:

- BM52T
- Electronic clock
- automatic start
- heating-up control
- cookControl, 10
- Bar handle
- Supporting systems: Programs
- Interior lighting
- Integral cooling fan

Accessory:

- 1 x air fry & grill tray, 1 x combination grid, 1 x deep tray, 1 x universal pan

Environment and Safety:

- Child lock
- Automatic switch off
- Start-/Stop button
- Door contact switch

Technical Info:

- Length of mains cable: 120 cm
- Nominal voltage: 220 - 240 V
- Total connected load electric: 3.4 KW
- Energy efficiency rating (acc. EU Nr. 65/2014): A
- Energy consumption per cycle in conventional mode: 0.98 kWh
- Energy consumption per cycle in fan-forced convection mode: 0.83 kWh
- Number of cavities: 1
- Heat source: electrical
- Cavity volume: 76 l

Dimensions:

- Appliance dimension (H x W x D): 595 mm x 594 mm x 548 mm
- Niche dimension (hxwx): 560 mm - 568 mm x 450 mm - 455 mm x 550 mm
- “Please reference the built-in dimensions provided in the

Series 4, Built-in oven with added steam function, 60 x 60 cm, Stainless steel

HUA736ER0

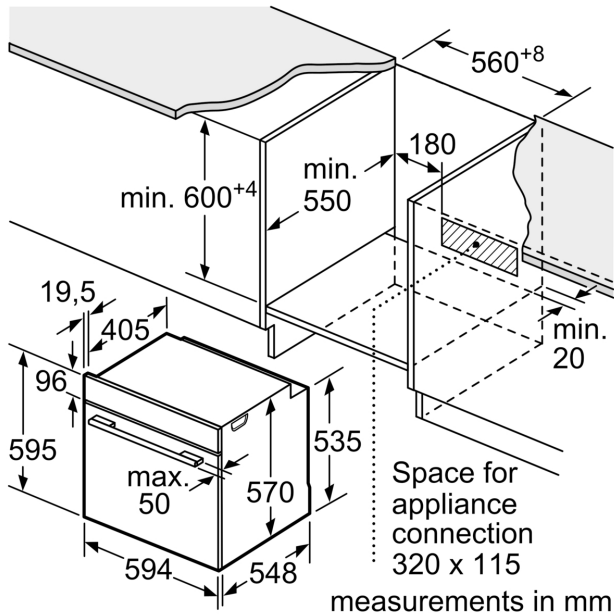

measurements in mm

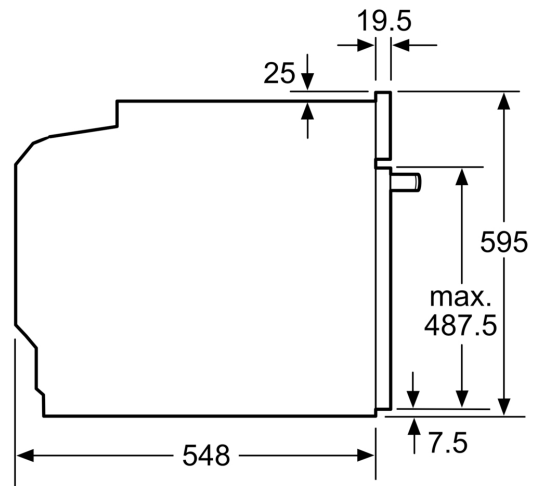

measurements in mm

Measurements in mm

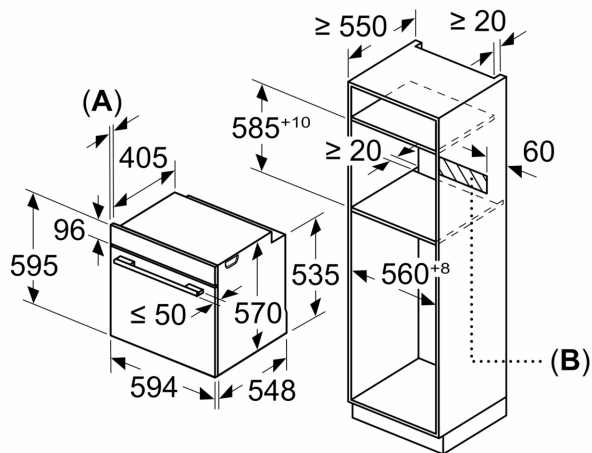

A: 19,5 mm

B: Space for appliance connection 320 x 115 mm

Installation with a hob.

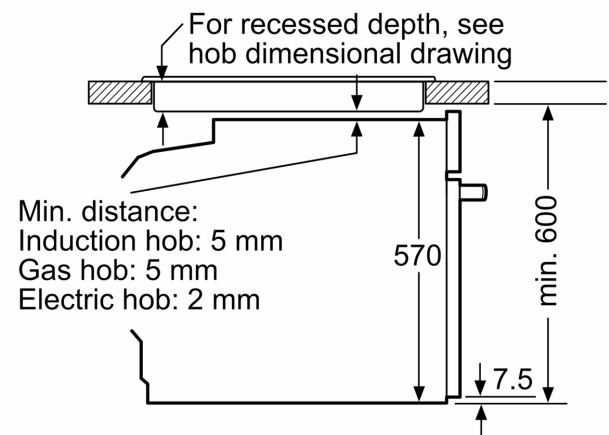

Min. distance:
 Induction hob: 5 mm
 Gas hob: 5 mm
 Electric hob: 2 mm

measurements in mm