

**Series 4, American side by side,
178.7 x 90.8 cm, Brushed steel (with
anti-fingerprint), Total No Frost
KAN93VIFPG**



Energy Efficiency Class (Regulation (EU) 2017/1369):	F
Average annual energy consumption in kilowatt hour per year (kWh/a) (EU) 2017/1369:	413 kWh/annum
Sum of volume of frozen compartments (EU 2017/1369):	208 l
Sum of volume of chill compartments:	372 l
Airborne acoustical noise emissions :	42 dB(A) re 1 pW
Airborne acoustical noise emission class (EU 2017/1369):	D
Built-in / Free-standing:	Free-standing
Number of compressors:	1
Number of independent cooling systems:	1
Width of the appliance:	908 mm
Height:	1787 mm
Depth of the product:	707 mm
Net weight:	96.4 kg
Door panel options:	Not possible
Door hinge:	left and right
Number of Adjustable Shelves in fridge compartment:	0
Shelves for Bottles:	No
Frost free system:	Fridge
Interior ventilator:	No
Reversible Door Hinge:	No
Length electrical supply cord:	200 cm
Noise level:	42 dB(A) re 1 pW
Multi-Flow Air Tower:	Yes
Fast cooling switch:	Yes
Fast freezing function:	Yes
Temperature Controlled Drawer:	No
Humidity Control Drawer:	No
Number of Door Bins - Refrigerator:	5
Door bin adjustability - Refrigerator:	Yes
Tilt-out door bins in fridge:	No
Number of Gallon storage:	3
Shelf Adjustability - Freezer:	Yes
Connection rating:	230 W
Fuse protection:	13 A
Voltage:	220-240 V
Frequency:	50 Hz
Storage Period in Event of Power Failure (h):	4 h
Color / Material body:	Grey
Door panel options:	Not possible
Noise level:	42 dB(A) re 1 pW
ENERGY STAR® certified:	No
Required cutout/niche size for installation (in):	X
Dimensions of the packed product:	73.62 x 37.79 x 30.70
Net weight:	212.000 lbs
Gross weight:	236.000 lbs



Series 4, American side by side, 178.7 x 90.8 cm, Brushed steel (with anti-fingerprint), Total No Frost KAN93VIFPG

- A large capacity Stainless Steel designed side-by-side fridge-freezer with VariolInverter and intuitive LED electronic control

General Data

- Gross Capacity (Total) : 616 L
- Net Capacity (Total) : 560 L
- Net Capacity (Fridge) : 371 L
- Net Capacity (Freezer) : 189 L
- Appliance Height : 1787 mm
- Appliance Width : 908 mm
- Appliance Depth : 707 mm
- Gross Weight: 110.0 Kg
- Net Weight: 99.9 Kg

Cooling System

- NoFrost - Saves you time and effort from defrosting.
- Supercooling - Automatically brings down the temperature of the refrigerator to cool new groceries rapidly.
- Multiairflow system - Minimises fluctuating temperatures by ensuring optimal and uniform air circulation in the fridge.

Convenience & Safety

- LED illumination in fridge and freezer sections
- Digital LED electronic panel
- Separate temperature controls for Fridge and Freezer
- Alarm system to alert the prolonged opening of refrigerator doors

Fridge Compartment

- 2 Pull out drawer, incl. 1Multibox
- 5 safety glass shelves
- 3 door trays (large)
- 2 door trays (small)

Freezer Compartment

- 2 Pull out drawer, incl. 1 Big Box for large size storing
- 2 storage drawers on extension rail systems for easy pull-out
- 5 glass shelves
- 5 door Bins
- Easy twist ice box
- Freezing capacity of 12 kg/24h

Design and Styling

- Stainless-steel with fingerprint resistant door finishing for easy cleaning
- Integrated vertical handle

Accessories

- 1 Egg tray(s)

**Series 4, American side by side,
178.7 x 90.8 cm, Brushed steel (with
anti-fingerprint), Total No Frost
KAN93VIFPG**

Measurements in mm

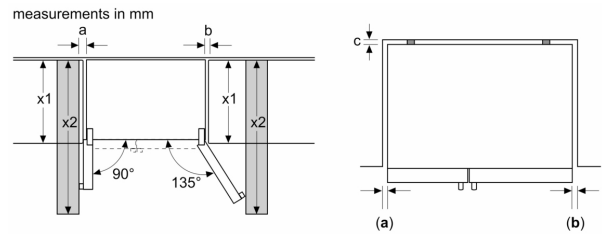
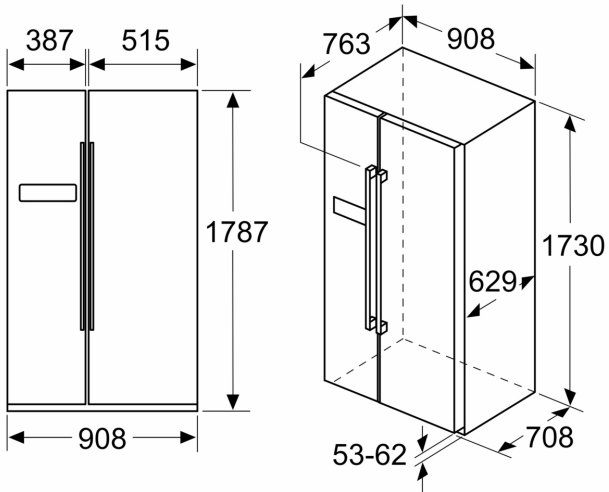

x1 (unit depth)	a	b
600	20	26