

## Series 4, free-standing freezer, 186 x 60 cm, Brushed steel anti-fingerprint GSN36VIEP



- **Vario Zone:** more flexibility due to variable-use glass shelves and drawers in the freezer compartment.
- **No Frost:** you'll never have to defrost your freezer again.
- **BigBox drawer:** For stacking storage containers or for large frozen food items.

Energy Efficiency Class (Regulation (EU) 2017/1369):	..... E
Average annual energy consumption in kilowatt hour per year (kWh/a) (EU) 2017/1369:	.....234 kWh/annum
Sum of volume of frozen compartments (EU 2017/1369):	..... 242 l
Airborne acoustical noise emissions :	.....39 dB(A) re 1 pW
Airborne acoustical noise emission class (EU 2017/1369):	..... C
Product category:	..... Upright freezer
Built-in / Free-standing:	..... Free-standing
Frost free system:	..... Fridge
Climate class:	..... SN-T
Door panel options:	..... Not possible
Width of the appliance:	..... 600 mm
Depth of the product:	..... 650 mm
Dimensions of the packed product (HxWxD):	.....1925x660x765 mm
Warning signal / malfunction:	..... Both visual and audible
Defrost:	..... Automatic
Cover door installation system:	.....Not applicable
Number of drawers/baskets (Stck):	..... 4
Number of freezing flaps (Stck):	..... 0
Lockable door:	..... No
Thermometer freeze section:	..... Digital
Length electrical supply cord:	..... 230 cm
Door hinge:	..... Right reversible
Net weight:	..... 66.9 kg
Gross weight:	..... 72.5 kg
Multi-Flow Air Tower:	..... Yes
Number of compressors:	..... 1
Number of independent cooling systems:	..... 1
Economy setting:	..... No
Fast freezing function:	..... Yes
Number of Door Bins - Freezer:	..... 0
Door bin adjustability - Freezer:	..... No
Tilt-out door bins in freezer:	..... No
Door bin adjustability - Freezer:	..... No
Reversible Door Hinge:	..... Yes
Fuse protection:	..... 10 A
Frequency:	..... 50 Hz
Door panel options:	..... Not possible
Installation typology:	..... Free-standing
Noise level:	..... 39 dB(A) re 1 pW
ENERGY STAR® certified:	..... No
Plug type:	..... Gardy plug w/ earthing
Required cutout/niche size for installation (in):	..... x
Dimensions of the packed product:	..... 75.78 x 25.98 x 30.11
Net weight:	..... 147.000 lbs
Gross weight:	..... 160.000 lbs
Included accessories:	..... 2 x cold accumulator, 1 x ice cube tray



## Series 4, free-standing freezer, 186 x 60 cm, Brushed steel anti-fingerprint GSN36VIEP

---

- Full no frost, Free-standing upright-freezer (> 90 cm h)

### Performance and consumption

- EU19\_EEK\_D: E
- Annual Energy Consumption: 234 kWh/a kWh/a
- Noise Level : 39 dB dB
- Total Volume : 242 l l
- yes

### Design and Styling

- Doors Inox-easyclean, side panels Pearl grey (VZF 07127)
- vertical bar handle

### Convenience & Safety

- Full no frost - never again defrosting!
- Super Freezing: Manual/automatic activation

### Freezer Section

- Net Freezer Volume : 242 l l
- Freezing capacity 24h : 18 kg kg
- Multi Airflow
- 1 ice cube tray
- Temperature rise time : 9 H H

### Dimensions

- Appliance Dimensions ( H x W x D): 186.0 cm x Appliance width: 60 cm x 65.0 cm

### Technical Information

- Height adjustable front feet, rolls in the back
- Nominal voltage: 220 - 240 V
- Climate Class: SN-T

### Accessories

- cold accumulator
- ice cube tray

### Country Specific Options

- Based on the results of the standard 24-hour test. Actual consumption depends on usage/position of the appliance.

### Special Accessories

### Environment and Safety

### Installation

### General Information

## Series 4, free-standing freezer, 186 x 60 cm, Brushed steel anti-fingerprint GSN36VIEP

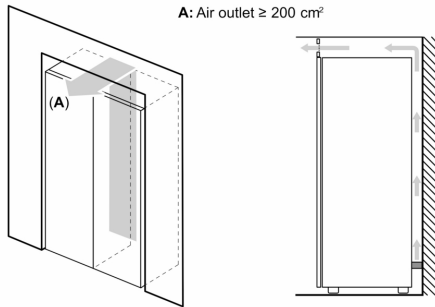

	a	b	c	d	e	f
KSW36, GSD36	187					
KSV36, KSF36, GSN36, GSV36	186					
KSV33, GSN33, GSV33	176	60	65	58	60	119.5
KSV29, GSN29, GSV29	161					
GSV24	146					
GSN51	161					
GSN54	176	70	78	70	70	142
GSN58	191					

a Height  
b Width  
c Depth with closed door w/o handle and w/o distance part  
d Depth of cabinet w/o distance part  
e Width with open door w/o handle  
f Depth with open door w/o handle w/o distance part

measurements in cm

