

**Series 4, Built-In Microwave,
Stainless steel
BEL523MS0B**



1 x grid, 1 x Turntable

HEZ86D000 Steamer Cooker Accessory for Microwave

- **AutoPilot 8:** every dish is a perfect success thanks to 8 pre-set automatic programmes.
- **LED-display control, red:** easy-to-use thanks to the time functions.
- **Pop-out controls:** Make the front of the oven easy to clean and give it a sleek look.
- **Stainless steel interior:** easy to clean interior thanks to smooth surfaces and no sharp edges.
- **Electronical door opening:** comfortable door opening just with a fingertip on the sensor button.

Additional function:Grill function
 Type of control:Electronic
 Dimensions: 382x594x317 mm
 Cavity dimensions: 201.0 x 308.0 x 282.0 mm
 Length electrical supply cord: 130.0 cm
 Net weight: 16.7 kg
 Gross weight: 19.0 kg
 Max. microwave power level: 800 W
 Number of Power Levels: 5
 Turntable:Yes
 Cavity material: Stainless steel
 Door opening: Button
 Clock:Yes
 Included accessories: 1 x grid, 1 x Turntable
 Height of the appliance: 382 mm
 Width of the appliance: 594 mm
 Depth of the product: 317 mm
 Max. microwave power level: 800 W
 Connection rating: 1270 W
 Fuse protection:10 A
 Voltage: 230-240 V
 Frequency: 50 Hz
 Plug type: GB plug
 Required cutout/niche size for installation (in):X
 Dimensions of the packed product: 17.71 x 14.96 x 25.98
 Net weight:37.000 lbs
 Gross weight: 42.000 lbs



Series 4, Built-In Microwave, Stainless steel BEL523MS0B

Microwave and heating mode:

- Max. Power: 900 W; 5 Microwave power settings: 90 W, 180 W, 360 W, 600 W, 900 W
- Grill 1.2 KW
- Grill and microwave power levels 90 W, 180 W, 360 W combinable
- Microwave and grill for separate use
- Cavity volume: 25 l

Design

- Stainless steel cavity

Comfort

- LED display control
- Electronic clock
- User-friendly electronics: extremely easy and comfortable operation
- AutoPilot 20
- 4 defrost and 3 cooking programmes in microwave function, 1 programmes for combination function
- Memory for individual programmes (1 setting)
- Halogen interior lighting
- 31.5 cm glass turntable
- Oven door with SoftOpen and SoftClose, Drop down door

Accessory

- combination grid, universal pan

Environment and Safety:

- Child lock Automatic switch off Residual heat indicator Start-/Stop button Door contact switch
- Integral cooling fan

Technical Information

- Length of mains cable: 120 cm
- Total connected load electric: Total connected load electric: 1.27 KW KW
- Nominal voltage: 220 - 240 V
- Suitable for high cupboard installation, Can be built in a 60 cm wall cupboard (at least 30cm deep)

Dimensions:

- Appliance dimension (hxwx): 595 mm x 594 mm x 548 mm
- Niche dimension (hxwx): 575 mm-597 mmx560 mm-568 mmx550 mm
- "Please reference the built-in dimensions provided in the installation drawing"

**Series 4, Built-In Microwave,
Stainless steel
BEL523MS0B**

Microwave,
corner installation

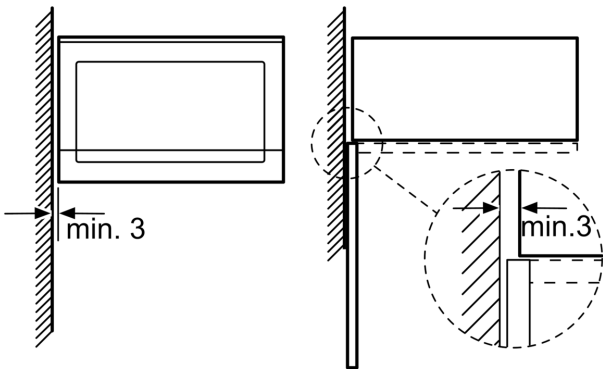

Measurements in mm

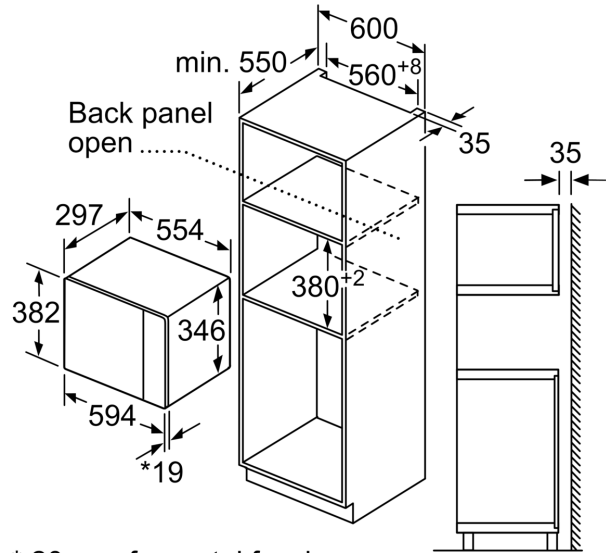

* 20 mm for metal fascia

measurements in mm

Measurements in mm

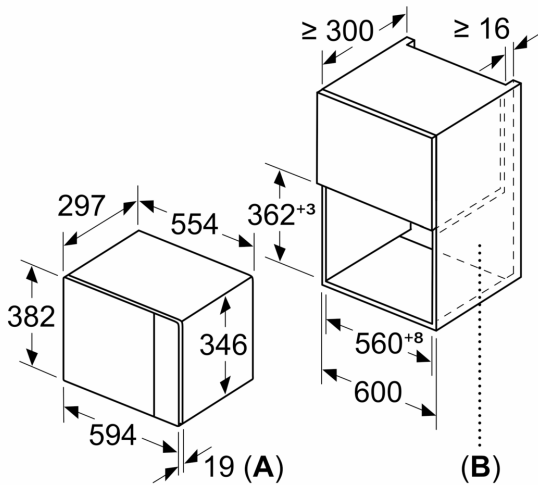

A: 20 mm for metal fascia
B: Back panel open

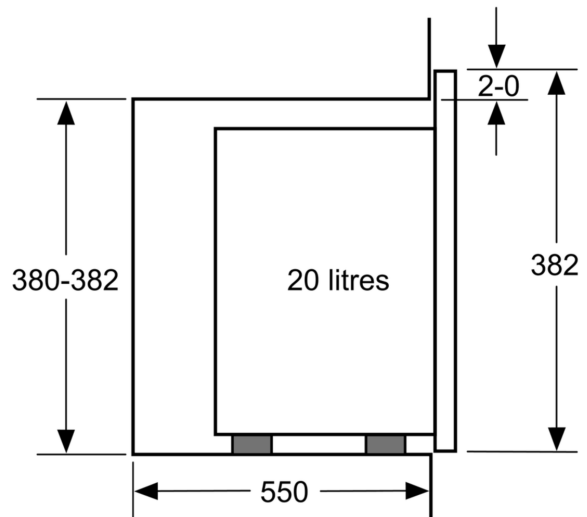

measurements in mm

