

Electric Cooktop, Black, surface mount with frame NET5054UC

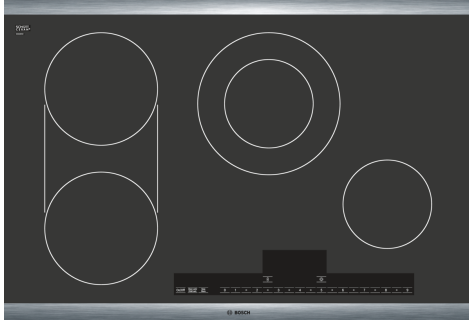

- **PreciseSelect® - Direct Cooking Level Selection (17 Settings)**
- **Sleek Touch Control Panel Offers a Choice of 17 Settings for Unprecedented Temperature Control.**
- **Bridge Element Accomodates Oblong or Oversized Pans and Griddles**
- **Dual Elements Offer the Capability to use Multiple Pan Sizes**
- **High-end Stainless Steel Frame for a Premium Look**

UPC code: 825225867623
 Color: Black
 Energy source: Electric
 Fuse protection:32 A
 Volts: 240/208 V
 Frequency: 60 Hz
 Plug type:no plug
 Required Cutout Size (HxWxD) (in):4" x 28 7/8" x 20"
 Minimum distance from counter front (in): 2 1/4"
 Minimum distance from rear wall (in): 2"
 Overall appliance dimensions (HxWxD) (in): .. 1/4"+4" x 31" x 21 1/4"
 Product Packaging Dimensions (HxWxD): 7 7/8" x 37 3/8" x 24"
 Net Weight: 27.000 lbs
 Gross weight: 35.000 lbs
 Total number of cooktop burners: 4



Electric Cooktop, Black, surface mount with frame NET5054UC

Key Features

- PreciseSelect® - Direct Cooking Level Selection (17 Settings)
- Sleek Touch Control Panel Offers a Choice of 17 Settings for Unprecedented Temperature Control.
- Bridge Element Accommodates Oblong or Oversized Pans and Griddles
- Dual Elements Offer the Capability to use Multiple Pan Sizes

Design

- High-end Stainless Steel Frame for a Premium Look

Performance

Convenience

- CleanLock - Prevents Unwanted Changing of Setting While Cleaning Spills
- Keep Warm function - allows meals to remain ready to serve
- Two-Level Heat Indicator - Warns if Cooktop is Warm or Hot
- ChildLock - Prevents the Cooktop from Being Accidentally Switched On, Locks Temperature Settings if in Use

**Electric Cooktop, Black, surface
mount with frame
NET5054UC**

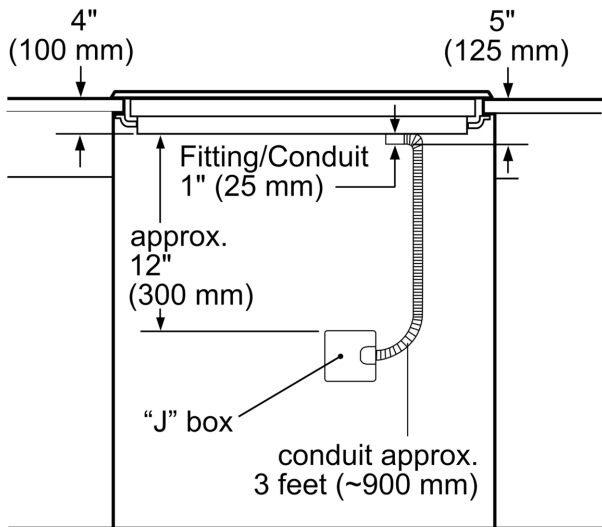

measurement in inches (mm)

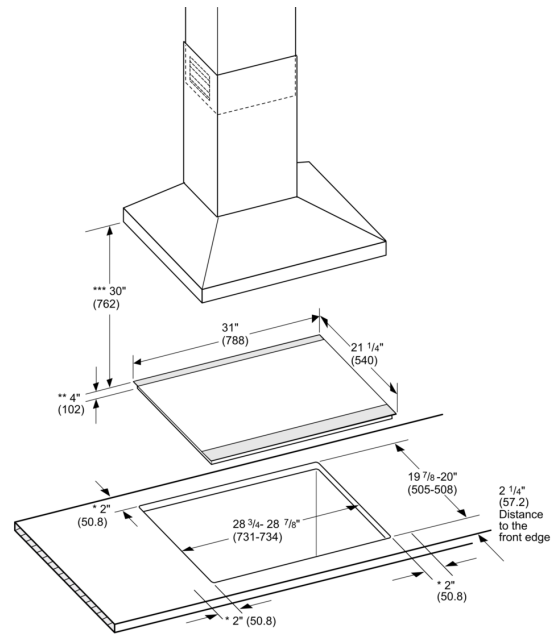

- * Minimum distance from the cooktop cutout to the wall
- ** Maximum cutout depth
- *** Minimum distance between the cooktop surface and lower edge of the exhaust hood.

Dimensions in inches (mm)