

**Series 6, heat pump tumble dryer, 9 kg**  
**WTR85T00TH**



- WTZ1110 Condenser drainage kit
- WTZ11400 Stacking kit with pull-out shelf
- WZ11410 Stacking kit

**Perfect drying results everytime**

- **Easy Clean with A++:** dries very efficient. With easy cleaning of the condenser filter.
- **AutoDry:** gently dries laundry to precisely the degree of dryness you want.
- **Big LED Display:** easy operation and extra functions available.
- **Sensitive Drying system combines warm air currents and a gentle drum structure for dry clothes**
- **Anti-crease: laundry is automatically loosened once program finished and does not crease.**

---

Built-in / Free-standing: ..... Free-standing  
 Removable top: ..... No  
 Door hinge: ..... Right  
 Color / Material body: ..... White  
 Length electrical supply cord: ..... 145.0 cm  
 Height of removable worktop: ..... 0 mm  
 Dimensions: ..... 842 x 598 x 613 mm  
 Net weight: ..... 49.5 kg  
 Drum volume: ..... 112 l  
 Fluorinated greenhouse gases: ..... No  
 Type of refrigerant: ..... R290  
 Hermetically sealed equipment: ..... Yes  
 The quantity expressed in CO2 equivalent: ..... 0.000 t  
 Connection Rating: ..... 600 W  
 Fuse protection: ..... 10 A  
 Voltage: ..... 220-240 V  
 Frequency: ..... 50 Hz  
 Drying process: ..... automatic  
 Capacity cotton - NEW (2010/30/EC): ..... 9.0 kg  
 Energy efficiency rating: ..... A++  
 Energy consumption electric dryer, full load - NEW (2010/30/EC) 2.08 kWh  
 Standard cotton programme time at full load: ..... 225 min  
 Energy consumption electric dryer, partial load - NEW (2010/30/EC): ..... 1.23 kWh  
 Standard cotton programme time at partial load: ..... 137 min  
 Weighted annual energy consumption, electric dryer - NEW (2010/30/EC): ..... 258.0 kWh/annum  
 Power consumption in off-mode - NEW (2010/30/EC): ..... 0.10 W  
 Power consumption in left-on mode - NEW (2010/30/EC): ..... 0.75 W  
 Weighted programme time: ..... 175 min  
 Condensation efficiency class - NEW (2010/30/EC): ..... B  
 Average condensation efficiency full load (%): ..... 83 %  
 Average condensation efficiency partial load (%): ..... 83 %  
 Weighted condensation efficiency (%): ..... 83 %



## Series 6, heat pump tumble dryer, 9 kg WTR85T00TH

### Perfect drying results everytime

---

#### Technical Information

- Capacity: 9 kg
- Dimensions (H x W x D): 84.2 x 59.8 x 61.3 cm
- 39 cm porthole, 170 ° swing door
- Drum volume: 112L
- Operating noise for drying: 64dBA

#### Programmes

- Cottons Cupboard Dry EXtra, Cottons Cupboard Dry, Cottons Iron Dry, Sportswear, Allergy+, Mix, Timed program warm, Timed Programme cold, Wool finish, Down, Super 40', Super 15', Easy Care Iron Dry, Easy Care Cupboard Dry, Easy Care Cupboard Dry Extra

#### Features

- Sensitive Drying system combines warm air currents and a gentle drum structure for dry clothes
- Fine-adjustment of drying intensity to customise your preferred level of dryness
- Anti-crease cycle 60 min at the end of programme
- Touch Control buttons: Low heat, less ironing, programme length, start/pause, fine-tuning of drying aim, 24h end time delay
- Anti-Vibration Side Panels reduce vibrations and ensure greater stability during the washing and spinning process.

#### Display Screen & Alerts

- LED Display for remaining time and 24 Hr end time delay, programme status indication, special functions
- Buzzer at the end of the wash programme

#### Safety

- Child-proof lock
- Duo-Tronic Senors monitors moisture levels and temperature to reach desired levels of dryness and to prevent overheating

**Series 6, heat pump tumble dryer, 9  
kg  
WTR85T00TH**

Measurements in mm

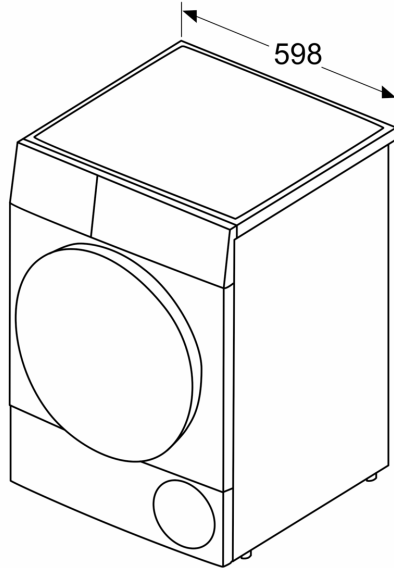

Measurements in mm

