

**Series 2, condenser tumble dryer, 7 kg, White
WTE84100TH**



7 Energy Stars, Excellent Energy Efficiency and Drying Performance

Built-in / Free-standing: Free-standing
 Removable top: Yes
 Door hinge: Right
 Color / Material body: White
 Length electrical supply cord: 145.0 cm
 Dimensions: 842x598x626 mm
 Net weight: 38.5 kg
 Drum volume: 112 l
 Connection Rating: 2100 W
 Fuse protection: 10 A
 Voltage: 220-240 V
 Frequency: 50 Hz
 Drying process: automatic
 Capacity cotton - NEW (2010/30/EC): 7.0 kg
 Energy efficiency rating: C
 Energy consumption electric dryer, full load - NEW (2010/30/EC) 4.28 kWh
 Standard cotton programme time at full load: 131 min
 Power consumption in off-mode - NEW (2010/30/EC): 0.10 W
 Power consumption in left-on mode - NEW (2010/30/EC): 1.00 W
 Condensation efficiency class - NEW (2010/30/EC): B
 Average condensation efficiency full load (%): 89 %
 Average condensation efficiency partial load (%): 89 %
 Weighted condensation efficiency (%): 89 %

- WZ20160 Condenser drainage kit
- WZ20290 Cover plate
- WZ20300 Stacking kit with pull-out shelf
- WZ20310 Stacking kit



Series 2, condenser tumble dryer, 7 kg, White WTE84100TH

7 Energy Stars, Excellent Energy Efficiency and Drying Performance

Technical Information

- Capacity: 7 kg
- Dimensions (H x W x D): 84.2 x 59.8 x 62.6 cm
- 39 cm porthole, 180 ° swing door
- Noise level: 65 dB (A) re 1 pW

Programmes

- Cottons Cupboard Extra Dry, Cottons Cupboard Dry, Cottons Iron Dry, Timed Dry 20 min warm, Mix/Cupboard Dry, Super 40', Easy Care Iron Dry, Easy Casre Cupboard Dry, Easy Care Cupboard Dry Extra

Features

- Self-Cleaning Condenser automatically cleans itself and keeps the dryer running at peak efficiency at all times
- Sensitive Drying system combines warm air currents and a gentle drum structure for dry clothes
- Anti-crease cycle 60 min at the end of programme
- Touch Control buttons: Low heat, less ironing, programme length, start/pause, fine-tuning of drying aim, 24h end time delay
- Anti-Vibration Side Panels reduce vibrations and ensure greater stability during the washing and spinning process.

Display Screen & Alerts

- LED Display for remaining time and 24 Hr end time delay, programme status indication, special functions
- Buzzer at the end of the wash programme

Safety

- Child-proof lock
- DUO-Tronic Sensors monitors moisture levels and temperature to reach desired levels of dryness and to prevent overheating

**Series 2, condenser tumble dryer, 7
kg, White
WTE84100TH**

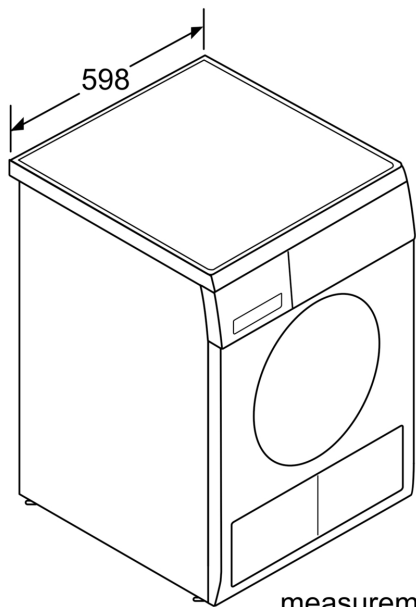

measurements in mm

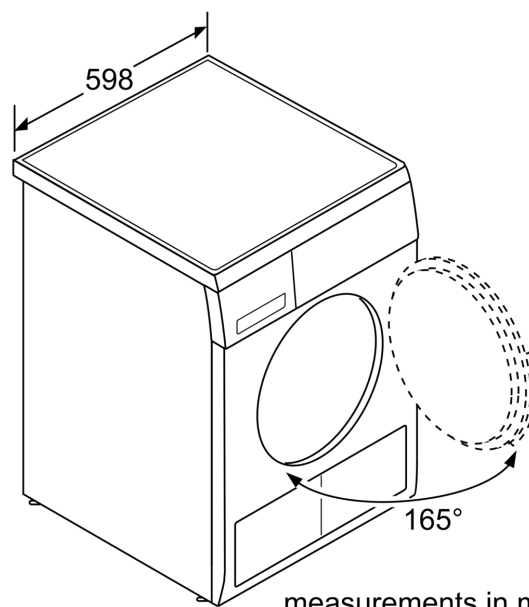

measurements in mm

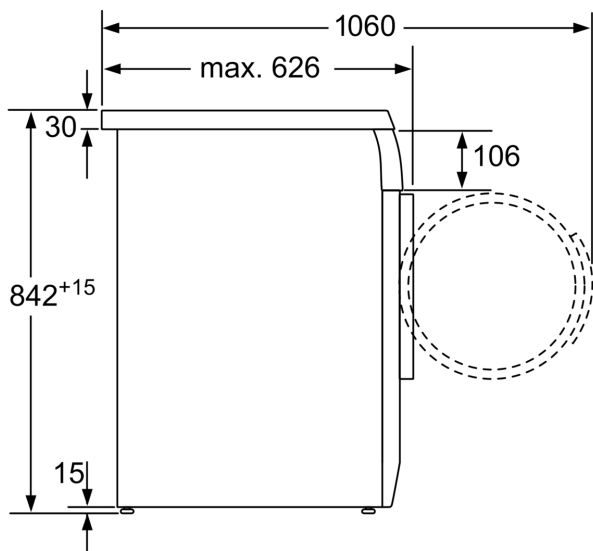

measurements in mm

Measurements in mm

