

**Series 6, washing machine, front loader, 9 kg, 1400 rpm WGG444E0TH**



**Remove common stains quickly and easily with Bosch Anti-Stain technology for greater peace of mind everytime.**

- **EcoSilence Drive™** friction-free motor minimises heat and wear for long-lasting performance, quiet operation and perfect wash results.
- **SpeedPerfect:** perfectly clean in up to 65% less time.
- **Vario Drum:** gently and efficiently wash with even water distribution and without creasing garments.
- **Active Water Plus:** For highly efficient use of water even with smaller loads thanks to automatic load detection.

- WMZ2200 Floor securing component  
 WMZ2381 Extension for cold water inlet /Aquastop  
 WMZPW20W Platform with pull-out, washer, cubic

---

Built-in / Free-standing: .....	Free-standing
Door hinge: .....	Left
Color / Material body: .....	White
Length electrical supply cord: .....	160.0 cm
Height of the appliance: .....	848 mm
Dimensions of the product: .....	848x598x590 mm
Wheels: .....	No
Net weight: .....	73.2 kg
Drum volume: .....	65 l
Door Frame: .....	Chrome, blackgray
Color Buttons: .....	black
Color Dial: .....	Chrome-black
Noise level washing: .....	44 dB(A) re 1pW
Connection Rating: .....	1900 W
Fuse protection: .....	10 A
Voltage: .....	220 V
Frequency: .....	50 Hz
Energy Star Qualified: .....	No
Cord Included: .....	Yes
Plug type: .....	Thai plug
Length of supply hose (in): .....	59.05 "
Dimensions of the packed product: .....	35.03 x 26.57 x 27.95
Net weight: .....	161.000 lbs
Gross weight: .....	170.000 lbs
Length of drain hose: .....	150.00 cm
Length of supply hose: .....	150.00 cm
Dimensions of the packed product (HxWxD): .....	890 x 675 x 710 mm
Gross weight: .....	77.0 kg
Connection Rating: .....	1900 W
Fuse protection: .....	10 A
Voltage: .....	220 V
Frequency: .....	50 Hz
Water protection system: .....	Multiple water protection
Maximum spin speed: .....	1400 rpm
Spin speed options: .....	Variable
Digital countdown indicator: .....	Yes
Drying progress indicator: .....	LED-display
Maximum capacity in kg (EU 2017/1369): .....	9.0 kg

---



## **Series 6, washing machine, front loader, 9 kg, 1400 rpm WGG444E0TH**

**Remove common stains quickly and easily with Bosch Anti-Stain technology for greater peace of mind everytime.**

---

### **Technical Information**

- Capacity: 9kg
- Maximum spin speed : 1400 rpm
- Dimensions (H x W x D): 84.8cm x 59.8 cm x 59.0 cm
- 32 cm porthole, 165° swing door

### **Programmes**

- Cottons, Mix Load, Synthetics, Delicates/Silk, Wool, SpinDrum Clean, Downs Clothes, Jeans, Bed Linen, Sensitive, Outdoor/Waterproofing, Quick 15 min
- Time delay to select end time of your wash (1 - 24 hours) and time remaining indicator
- Reload function to pause machine operation for adding in last minute laundry items

### **Features**

- AntiStain: Automatic stain removal of the most common stains
- EcoSilence Drive™ friction-free motor minimises heat and wear for long-lasting performance, quiet operation and perfect wash results.
- SpeedPerfect: perfectly clean in up to 65% less time.
- ActiveWater™ Plus: Pressure and water sensor that measures the washing load and adjusts water intake to 256 precise levels for more cost and water savings
- VarioDrum's breakthrough wave-droplet design provides a thorough yet gentle clean for fine textiles
- Anti-Vibration Side Panels reduce vibrations and ensure greater stability during the washing and spinning process.

### **Safety**

- Multiple water protection with magnetic valve to minimise risk of leakage
- Child-proof lock

### **Display Screen & Alerts**

- Large LED display screen to indicate: Programme status, Temperature and Spin Speed Selection, Remaining Time and 24 Hour End Time Delay, Load Recommendation and Consumption

**Series 6, washing machine, front loader, 9 kg, 1400 rpm  
WGG444E0TH**

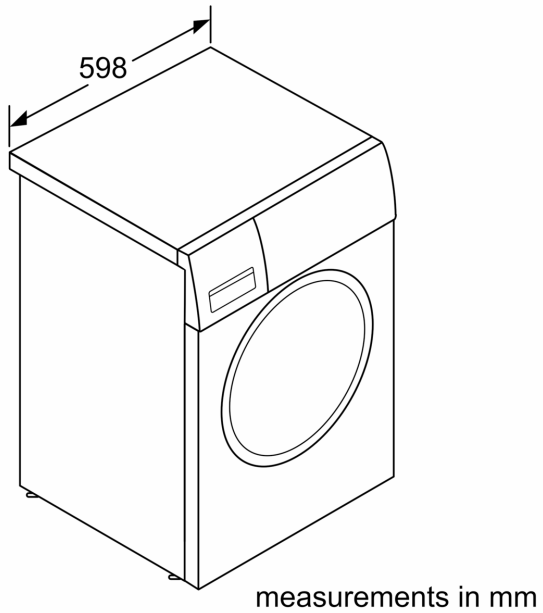

Measurements in mm

