

Series 4, 183 x 90.5 cm, Brushed steel anti-fingerprint KFN96APEAG



- **XXL capacity:** extra space for your food when you need it.
- **LED lighting:** keep your groceries in perfect view.
- **Big Box drawer:** for stacking storage containers or for large frozen food items.
- **Super Cooling function:** cools new food placed inside faster, thus protecting already cooled food.

Energy Efficiency Class (Regulation (EU) 2017/1369):	E
Average annual energy consumption in kilowatt hour per year (kWh/a) (EU) 2017/1369:	333 kWh/annum
Sum of volume of frozen compartments (EU 2017/1369):	200 l
Sum of volume of chill- and unfrozen compartments (EU 2017/1369):	405 l
Airborne acoustical noise emissions (EU 2017/1369):	38 dB(A) re 1pW
Airborne acoustical noise emission class (EU 2017/1369):	C
Built-in / Free-standing:	Free-standing
Number of compressors:	1
Number of independent cooling systems:	1
Width of the appliance:	905 mm
Height:	1830 mm
Depth of the product:	731 mm
Net weight:	118.3 kg
Door panel options:	Not possible
Door hinge:	left and right
Number of Adjustable Shelves in fridge compartment:	3
Shelves for Bottles:	No
Frost free system:	Fridge and freezer
Interior ventilator:	Yes
Reversible Door Hinge:	No
Length electrical supply cord:	240.0 cm
Noise level:	38 dB(A) re 1pW
Multi-Flow Air Tower:	Yes
Fast cooling switch:	Yes
Fast freezing switch:	Yes
Temperature Controlled Drawer:	No
Humidity Control Drawer:	No
Number of Door Bins - Refrigerator:	4
Door bin adjustability - Refrigerator:	Yes
Tilt-out door bins in fridge:	Yes
Gallon Storage:	Yes
Number of Gallon storage:	2
Motorized Shelf:	No
Material of the shelves:	Safety glass
Door opened indicator freezer:	Yes
Automatic motor-driven ice-maker:	No
Fuse protection:	10 A
Voltage:	220-240 V
Frequency:	50-60 Hz
Storage Period in Event of Power Failure (h):	15 h
Door panel options:	Not possible
Noise level:	38 dB(A) re 1pW
Energy Star Qualified:	No
Plug type:	GB plug
Required cutout/niche size for installation (in):	x
Dimensions of the packed product:	74.99 x 39.29 x 30.70
Net weight:	261.000 lbs
Gross weight:	284.000 lbs



Series 4, 183 x 90.5 cm, Brushed steel anti-fingerprint KFN96APEAG

- Free-standing-refrigerator >= 3 door, NoFrost
- inox EasyClean Doors

Consumption

Design and Styling

- Door inox EasyClean, side panels Metallic chrome
- Classic door , Door inox EasyClean, side panels Metallic chrome
- LED interior light in fridge section
- Interior with metal applications

Convenience & Safety

- 7 segment electronic control
- Supercool function with automatic
- Automatic defrost in fridge section
- acoustic for Fridge and Freeze, Optical warning system Door open
- Acoustic Warning System, Optical Warning System by Temperatur increase

Fridge Compartment

- Multi Airflow-System
- 2door trays (large)
- 2 door trays (small)
- none/0
- Dairy compartment

Freshness System

Freezer Compartment

- 6 transparent freezer drawers
- 1 Ice cube tray
- Without Illumination in freezer section

Appliance Dimension

- Appliance Height: 1830 mm
- Appliance Width:905 mm
- Appliance Depth:731 mm

TECHNICAL INFORMATION

- Rated Voltage 220 - 240 V

Accessories

- 3 x egg tray, 1 x ice cube tray
- Based on the results of the standard 24-hour test. Actual consumption depends on usage/position of the appliance.
- Acoustic Warning System
- 2 ldoor shelf, large
- LED interior light

Series 4, 183 x 90.5 cm, Brushed steel anti-fingerprint KFN96APEAG

Measurements in mm

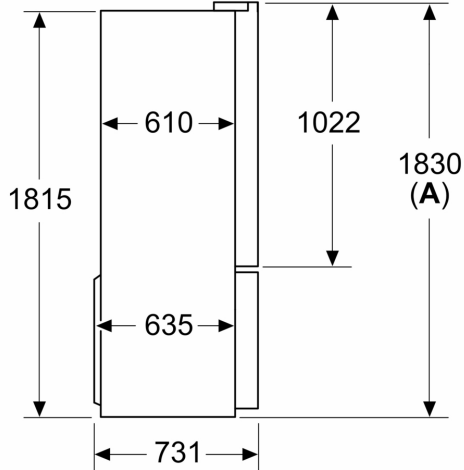

A: Front is adjustable 1830–1847 mm, with front levelling feet fully extended

Measurements in mm

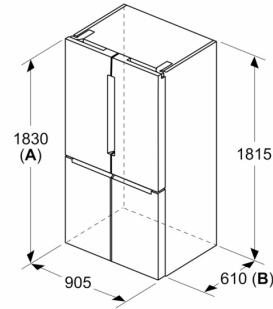

A: Front is adjustable 1830–1847 mm, with front levelling feet fully extended

B: Add 25 mm for fixed spacers on back

Measurements in mm

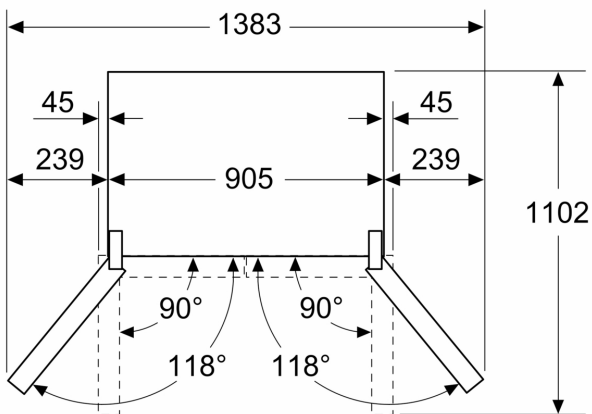

Measurements in mm

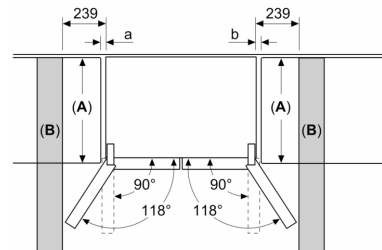

A	a	b
≤ 600	0	0
600 < A ≤ 650	45	45
650 < A ≤ 700	60	60
> 700	239	239

A: Kitchen cabinet or worktop depth

B: Wall
Drawers can be pulled and taken out with door open to 90°