

**Series 8, Built-in microwave oven,  
Stainless steel  
HMT85ML53**



**The built-in microwave for the 38 cm niche:  
use it for extra fast thawing, heating and  
perfect preparation of foods.**

- **LED-display control, red:** easy-to-use thanks to the time functions.
- **Pop-out controls:** for an easy to clean front.
- **Inverter Technology:** constant microwave power for heating food gradually.

---

**Technical Data**

Type of micro-wave oven : MW only  
Type of control : Electronic  
Color / Material Front : Stainless steel  
Dimensions : 382 x 595 x 320 mm  
Cavity dimensions : 220 x 350 x 270 mm  
Length electrical supply cord : 150.0 cm  
Net weight : 17.8 kg  
Gross weight : 20.2 kg  
Maximum micro-wave power : 900 W  
Number of Power Levels : 5  
Turntable : No  
Cavity material : Stainless steel  
Door opening : Button  
Clock : Yes  
Main colour of product : Stainless steel  
Height of the appliance : 382 mm  
Width of the appliance : 595 mm  
Depth of the product : 320 mm  
Maximum micro-wave power : 900 W  
Connection Rating : 1220 W  
Fuse protection : 10 A  
Voltage : 230 V  
Frequency : 50 Hz  
Plug type : GARDY plug w/ earthing  
Color / Material Front : Stainless steel  
Alternative colors available : HMT85ML23, HMT85ML63  
Required cutout/niche size for installation (in) : x x  
Dimensions of the packed product : 18.50 x 18.11 x 26.37  
Net weight : 39.000 lbs  
Gross weight : 45.000 lbs



## **Series 8, Built-in microwave oven, Stainless steel HMT85ML53**

**The built-in microwave for the 38 cm niche:  
use it for extra fast thawing, heating and  
perfect preparation of foods.**

---

### **Performance**

- Oven capacity: 21 litres
- 900 W - Microwave
- With Inverter technology
- 5 settings: 900 W, 600W, 360W, 180W, 90W

### **Functions**

- 3 PC
- 4 PC
- 2 PC
- 3 stage programming

### **Features**

- Large digital display for displaying cooking times and time of day

### **Design**

- Basic control knobs
- Push buttons
- Stainless steel interior
- Interior lighting
- Left hinged door

## Series 8, Built-in microwave oven, Stainless steel HMT85ML53

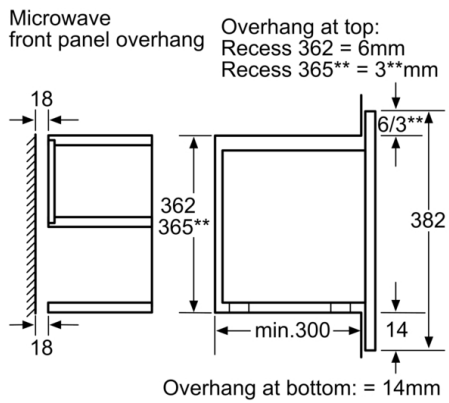

Measurements in mm

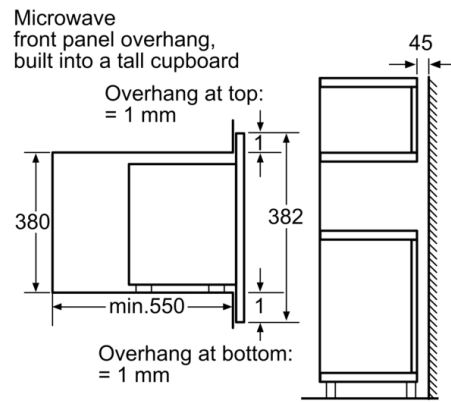

Measurements in mm

Microwave, corner installation

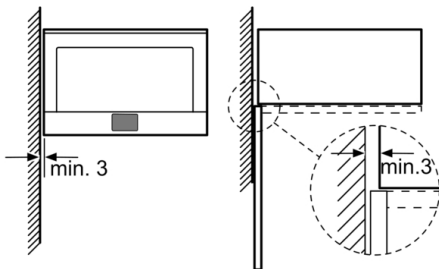

Measurements in mm

Microwave in a wall-hanging cupboard

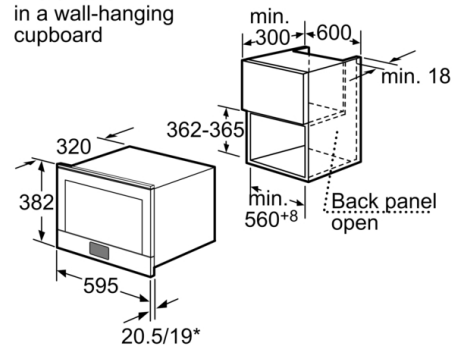

\* Colour-fronted appliances

Measurements in mm

Microwave in a tall cupboard

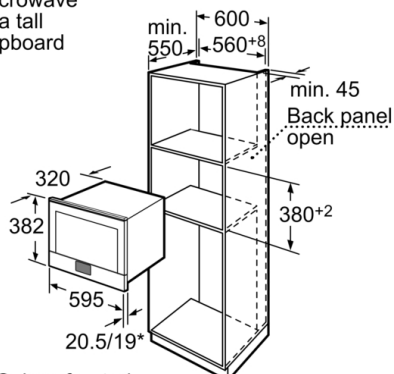

\* Colour-fronted appliances

Measurements in mm