

**Series 6, Built-in microwave oven, 59 x 38 cm, Stainless steel
HMT84G654B**

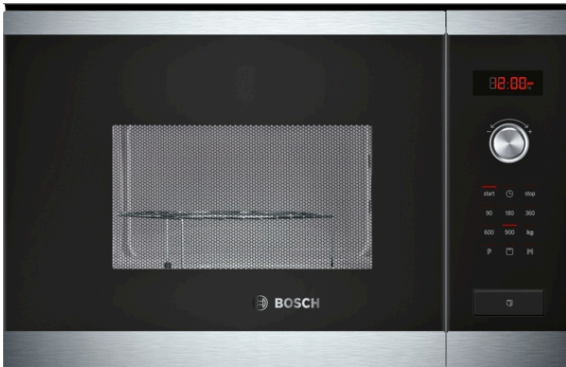

- **LED-display control, red:** easy-to-use thanks to the time functions.

Technical Data

Type of micro-wave oven : MW+Grill function
Type of control : Electronic
Color / Material Front : Stainless steel
Dimensions : 382 x 594 x 388 mm
Cavity dimensions : 208.0 x 328.0 x 369.0 mm
Length electrical supply cord : 130.0 cm
Net weight : 19.2 kg
Gross weight : 21.1 kg
Maximum micro-wave power : 900 W
Number of Power Levels : 5
Turntable : Yes
Cavity material : Stainless steel
Door opening : Button
Clock : Yes
Main colour of product : Stainless steel
Height of the appliance : 382 mm
Width of the appliance : 594 mm
Depth of the product : 388 mm
Maximum micro-wave power : 900 W
Connection Rating : 1450 W
Fuse protection : 10 A
Voltage : 230-240 V
Frequency : 50 Hz
Plug type : GB plug
Color / Material Front : Stainless steel
Required cutout/niche size for installation (in) : x x
Dimensions of the packed product : 17.32 x 17.71 x 26.37
Net weight : 42.000 lbs
Gross weight : 47.000 lbs



4 242002 788746

Series 6, Built-in microwave oven, 59 x 38 cm, Stainless steel HMT84G654B

Performance

- User-friendly electronics: extremely easy and comfortable operation
- Oven capacity 25 litres with stainless steel interior
- 5 power levels: 900 W, 600 W, 360 W, 180 W, 90 W
- Grill: 1200 W
- 315 mm turntable glass

Functions

- 8 - Automatic programmes
- 4 weight automatic defrost programmes
- 3 cooking programs
- 1 memory function

Features

- Electronic control
- timer up to 60 minutes
Automatic safety switch-off

Design

- Side opening door with viewing window
- Suitable for tall housing installation
- Interior lighting

**Series 6, Built-in microwave oven, 59 x 38 cm, Stainless steel
HMT84G654B**

Microwave,
corner installation

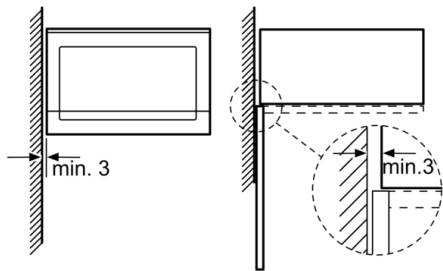

Measurements in mm

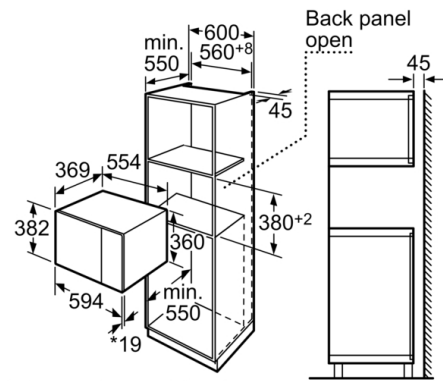

* 20 mm for metal fascias

measurements in mm

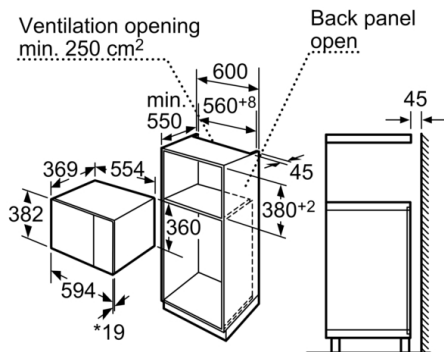

* 20 mm for metal fascias

measurements in mm