

**Series 8, Built-in microwave oven, 60 x 45 cm, Stainless steel  
HMT35M653B**



**The built-in microwave for the 45 cm niche:  
use it for extra fast thawing, heating and  
perfect preparation of foods.**

- **LED-display control, red:** easy-to-use thanks to the time functions.
- **Pop-out controls:** for an easy to clean front.
- **Inverter Technology:** constant microwave power for heating food gradually.

---

**Technical Data**

Type of micro-wave oven : MW only  
Type of control : Electronic  
Color / Material Front : Stainless steel  
Dimensions : 454 x 595 x 563 mm  
Cavity dimensions : 242.0 x 430 x 345.0 mm  
Length electrical supply cord : 150.0 cm  
Net weight : 25.7 kg  
Gross weight : 30.0 kg  
Maximum micro-wave power : 1000 W  
Number of Power Levels : 5  
Turntable : No  
Cavity material : Stainless steel  
Door opening : Handle  
Clock : Yes  
Main colour of product : Stainless steel  
Height of the appliance : 454 mm  
Width of the appliance : 595 mm  
Depth of the product : 563 mm  
Maximum micro-wave power : 1000 W  
Connection Rating : 1220 W  
Fuse protection : 10 A  
Voltage : 220-240 V  
Frequency : 50 Hz  
Plug type : GB plug  
Color / Material Front : Stainless steel  
Required cutout/niche size for installation (in) : x x  
Dimensions of the packed product : 22.44 x 26.37 x 25.98  
Net weight : 57.000 lbs  
Gross weight : 66.000 lbs



**Series 8, Built-in microwave oven, 60 x 45  
cm, Stainless steel  
HMT35M653B**

**The built-in microwave for the 45 cm niche:  
use it for extra fast thawing, heating and  
perfect preparation of foods.**

---

**Performance**

- Oven capacity: 36 litres
- 1000 W - Microwave
- With Inverter technology
- 5 settings: 1000 W, 600W, 360W, 180W, 90W

**Functions**

- Distribution system (MW): Stirrer fan
- 2 recipe memory settings

**Performance:**

- Control panel height 96mm: for a perfect horizontal combination with panorama appliances
- Large digital display for displaying cooking times and time of day
- One-knob control
- Push buttons
- Full metal bar handle
- U-shape glass on metal door design

**Series 8, Built-in microwave oven, 60 x 45 cm, Stainless steel  
HMT35M653B**

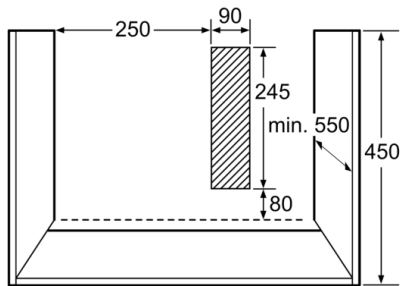

Measurements in mm

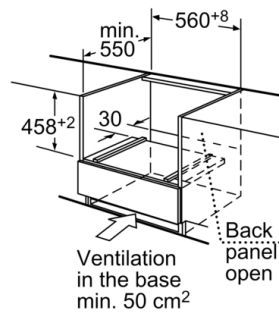

measurements in mm

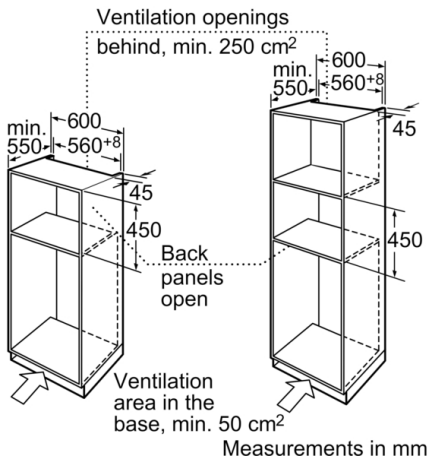

Measurements in mm

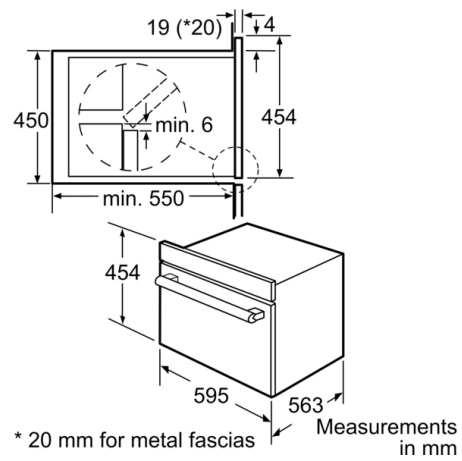

Measurements in mm