

**Series 2, Built-in oven, 60 x 60 cm,  
Stainless steel  
HBF011BR0K**



**The built-in oven with 3D hot air: achieve perfect baking and roasting results on up to three levels simultaneously.**

- **Hotair Gentle:** saves energy while baking and roasting.
- **3D hotair:** perfect results thanks to optimal distribution of heat on up to 3 levels simultaneously - without taste transfer.

1 x combination grid, 1 x universal pan

- HEZ317000 Pizza pan, enamelled
- HEZ327000 Pizza stone
- HEZ333001 Lid for professional pan
- HEZ429001 Air Fry & Grill tray, anthracite
- HEZ431002 Baking tray, enamelled
- HEZ625071 Grill tray, anthracite
- HEZ915003 Glass roasting dish, 5,4 L

Gross weight: ..... 33.9 kg  
 Built-in / Free-standing: ..... Built-in  
 Integrated Cleaning system: ..... No  
 Min. required niche size for installation (HxWxD): 575-597 x 560-568 x 550 mm  
 Dimensions: ..... 595x594x548 mm  
 Dimensions of the packed product (HxWxD): ..... 680 x 655 x 680 mm  
 Control Panel Material: ..... Stainless steel  
 Door Material: ..... Glass  
 Net weight: ..... 31.8 kg  
 Usable volume of cavity: ..... 66 l  
 Number of interior lights: ..... 1  
 Length electrical supply cord: ..... 200.0 cm  
 Interior Lights - cavity 1: ..... 1  
 Pull-out system: ..... Accessory  
 Included accessories: ..... 1 x combination grid, 1 x universal pan  
 Broil Element Wattages cavity 1: ..... 2800 W  
 Energy efficiency rating: ..... A  
 Energy consumption per cycle conventional (2010/30/EC): ..... 0.98 kWh/cycle  
 Energy consumption per cycle forced air convection (2010/30/EQ): 79 kWh/cycle  
 Energy efficiency index (2010/30/EC): ..... 95.2 %  
 Connection rating: ..... 3300 W  
 Fuse protection: ..... 16 A  
 Voltage: ..... 220-240 V  
 Frequency: ..... 50 Hz  
 Plug type: ..... no plug  
 Energy input: ..... Electric  
 Required cutout/niche size for installation (in): ..... x  
 Dimensions of the packed product: ..... 26.77 x 25.78 x 26.77  
 Net weight: ..... 70.000 lbs  
 Gross weight: ..... 75.000 lbs  
 Length electrical supply cord: ..... 200.0 cm  
 Net weight: ..... 31.8 kg



## **Series 2, Built-in oven, 60 x 60 cm, Stainless steel HBF011BR0K**

**The built-in oven with 3D hot air: achieve perfect baking and roasting results on up to three levels simultaneously.**

---

### **Heating Functions**

- Oven with 5 heating methods:
  - - Hot air gentle
  - - 3D hot air plus - Conventional heat - Hot air grilling - Full width variable grill
- Temperature range 50 °C - 275 °C
- Cavity volume: 66 L

### **Hook-in racks / rails**

- Large capacity oven with shelf supports

### **Design**

- Rotary control dials
- straight bar handle
- Full glass inner door

### **Comfort**

- LED display control (red)
- Door hinge: Bottom
- Rapid heating-up
- 1 x combination grid, 1 x universal pan

### **Technical Information**

- Length of mains cable: 200 cm
- Nominal voltage: 220 - 240 V
- Electrical connection rating: 3300 W
- Energy efficiency rating (acc. EU Nr. 65/2014):
- Energy consumption per cycle in conventional mode: 0.98 kWh
- Energy consumption per cycle in fan-forced convection mode: 0.79 kWh
- Number of cavities: 1 Heat source: electrical Cavity volume: 66 L

### **Technical information:**

- Dimensions of the product (HxWxD mm) : 595 x 594 x 548
- Required niche size for installation (HxWxD mm): 575 - 597 x 560 - 568 x 550
- "Please reference the built-in dimensions provided in the installation drawing"

**Series 2, Built-in oven, 60 x 60 cm,  
Stainless steel  
HBF011BR0K**

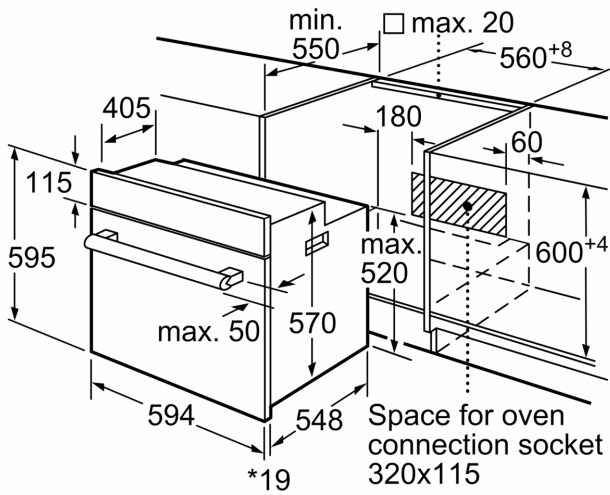

\* 20 mm for metal fascias

measurements in mm

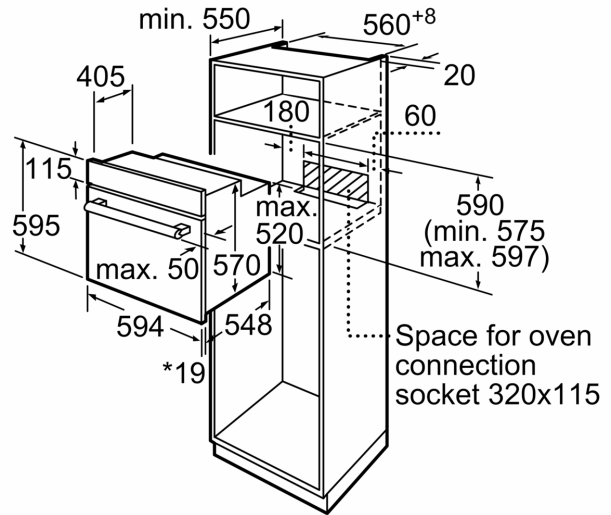

\* 20 mm for metal fascias

measurements in mm

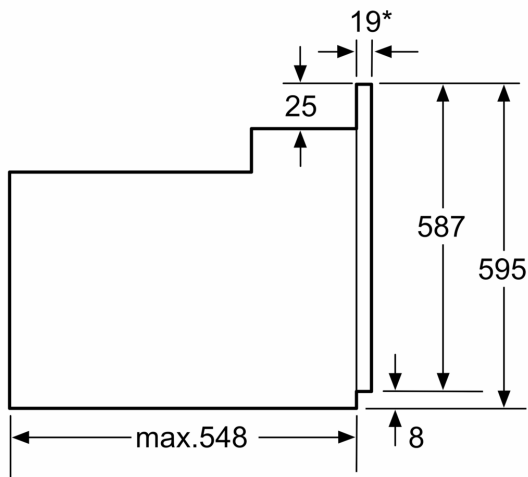

\* 20 mm for metal fascias

Dimensions in mm