

Series 6, Fully-integrated dishwasher SMV6HCX01A



Door panel not included. Match to kitchen cabinetry.



Optional accessories

SMZ5150AU : Kick panel stainless steel

SMZ5300 : GlassSecure Tray

Dishwasher with an Extra Clean Zone for difficult to clean dishes, and WiFi connectivity.

- **InfoLight:** a red light on the floor indicates whether the dishwasher is switched on or off.
- **VarioDrawer:** Provides a convenient third loading level for cutlery and utensils.
- **Extra Clean Zone:** extra thorough cleaning for items in the top basket.
- **HygienePlus option:** Extended increased temperature cycle for hygienic cleaning.
- **Home Connect:** Control & monitor your dishwasher remotely from your smartphone or tablet.

Technical Data

Water consumption : 11.0 l

Built-in / Free-standing : Built-in

Height of removable worktop : 0 mm

Dimensions of the product (HxWxD) : 815 x 598 x 550 mm

Required niche size for installation (HxWxD) : 815-875 x 600 x 550 mm

Depth with open door 90 degree : 1150 mm

Adjustable feet : Yes - all from front

Maximum adjustability feet : 60 mm

Net weight : 40.0 kg

Gross weight : 42.0 kg

Connection Rating : 2400 W

Fuse protection : 10 A

Voltage : 220-240 V

Frequency : 50; 60 Hz

Length electrical supply cord : 175 cm

Plug type : AU plug

Length inlet hose : 165 cm

Length outlet hose : 190 cm

EAN code : 4242005280797

Number of place settings : 15

Energy consumption : 0.65 kWh

Total cycle time of reference programme : 195 min

Noise level : 44 dB(A) re 1 pW

Installation typology : Full-integrated



4 242005 280797

Series 6, Fully-integrated dishwasher SMV6HCX01A

Dishwasher with an Extra Clean Zone for difficult to clean dishes, and WiFi connectivity.

Capacity

- 15 place setting capacity

Consumption rates

- 4 StarEnergy rating
- 5.5 Star WELS Water rating
- 11 litres water consumption per wash in accordance with AS/NZS 6400 and 245 kWh energy consumption per year, with Cold water connection using the Eco Wash program seven times per week. When tested in accordance with AS/NZS 2007.2. Actual energy use and running costs will depend on how you use the appliance.

Design

- InfoLight: program status indicator beams a red light onto the floor to let you know when the dishwasher is operating
- Hidden control buttons integrated into the top of the door
- Stainless steel interior tub with 10 year rust through warranty
- SoftTouch buttons: Electronic soft-touch activated buttons
- Time remaining display
- Audible program end indicator tone (can be turned on/off)
- Vapor barrier plate included

Wash Programs and Options

- 8Wash Programs:
 - Eco Wash 45 °C
 - Auto Wash 45-65 °C
 - Auto Gentle 35-45 °C
 - Pots/Pans 70 °C
 - Quick 1h 65 °C
 - Express Wash 45 °C
 - ExtraQuiet 50 °C
 - Favourite (Pre-Rinse is set as default)
- 4 special options:
 - Remote Start: Connect to WiFi via HomeConnect
 - Extra Dry: Provides an even better drying result by extending the drying time.
 - HygienePlus: Hotter final rinse, for increased hygiene that helps to remove bacteria
 - SpeedPerfect: Reduces the wash time, and can be activated at any moment (even after the wash program has started) via the SpeedPerfect button or via WiFi using the Home Connect app
- Machine Care: Maintains your dishwasher's optimum performance and hygiene.

Performance

- Extra Clean Zone: Provides an even better cleaning result for items placed directly over the three rotating nozzles in the top basket
- DosageAssist: Maximises the effectiveness of detergent tablets. The tablet is dropped into a specially engineered tray and is completely dissolved. For superior cleaning performance and a quieter wash
- EcoSilence Drive quiet and energy-efficient brushless motors (BLDC): Main Pump & Drain Pump. Variable water & spray pressure to achieve optimum cleaning results. Fast and extra quiet draining of water, no gargling sounds
- Aqua Sensor technology: Regulates the water usage depending on the type and degree of soiling.
- Load Sensor technology: Provides for optimal water usage even for half loads or partial loads, saving water and electricity.
- AutoBrilliance: Automatic detergent and rinse aid sensor
- Heat exchanger.
- 3 stage filter system, including an innovative micro filter with a corrugated design that conveniently helps to reduce the need to wash the filter and also helps to prevent blockages.
- 5 spray levels for maximum water contact and optimum wash results
- Quiet operation: 44 dB(A)
- Extra Quiet program noise level: 42 dB(A)
- Home Connect WiFi connectivity

Flexibility

- VarioDrawer: Provides an extra loading level for cutlery and utensils
- Max Flex basket system with red coloured touchpoints, easy to identify flexing & moving parts
- Rackmatic: the top basket can be adjusted to at various height levels to maximise convenience, and even utilised on an angle which helps prevent water pooling on the top of cups
- Anti-slip protection strips in top basket
- Smooth gliding basket wheels with ball bearings in the top basket
- Smooth gliding low friction wheels in the bottom basket
- 2 foldable plate racks in top basket
- 6 foldable plate racks in bottom basket
- 2 foldable cup shelves with soft silicone edges in top basket
- 2 foldable cup shelves in bottom basket
- Time delay start: Delay program start time by 1-24 hours to suit your schedule
- Moveable cutlery basket in bottom basket
- Rack Stopper to prevent derailing of bottom basket
- Large item spray head: For washing extra large items such as baking trays and rangehood filters
- Vapor barrier plate included

Safety

- AquaStop Plus: Water supply device with lifetime anti-flood protection
- Child door lock

Appliance dimensions and weight

- Appliance dimensions (HxWxD): 81.5-87.5 cm x 59.8 cm x 55 cm
- Packaging dimensions (HxWxD): 88 cm x 66 cm x 67 cm
- Gross Weight: 42 kg

Series 6, Fully-integrated dishwasher SMV6HCX01A

measurements in mm

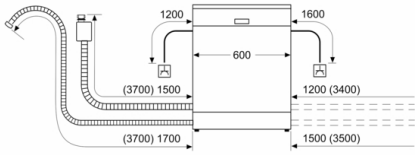

⌚ socket
() values with extension kit

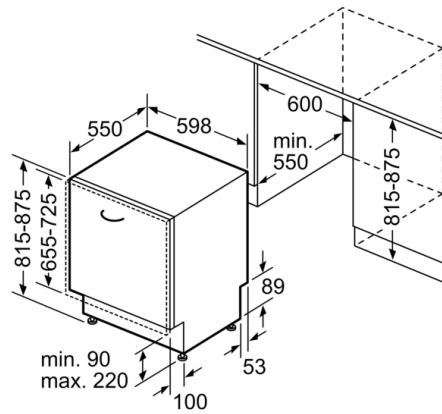

measurements in mm