

## Series 6, Induction cooktop, 70 cm, surface mount without frame PVQ731F15E



- **DirectSelect:** Direct, simple selection of the desired cooking zone, power and additional functions.
- **CombiZone:** combine two induction cooking zones to heat large cookware.
- **AutoOn function:** the extraction automatically switches on when the cooktop is activated.
- **Power Boost:** up to 35% faster heating compared to highest power level.
- **Restart:** restores cooktop settings in case of an unintentional switch-off.

1 x Slider for unducted recirculation, 1 x Clean Air Plus odor filter

HEZ9ES100 Espresso maker 4 cups, HEZ9FE280 Iron pan Ø 18 / 28 cm, HEZ9SE030 Set of 2 pots and 1 pan, HEZ9SE040 4 pieces Set, HEZ9SE060 6 pieces Set, HEZ9VDKE1 Exhaust kit, HEZ9VDKRO Recirculation kit 2 L-bow (70cm), HEZ9VDKR1 Recirculation kit S and L-bow (60cm), HEZ9VDKR2 Recirculation kit 1x L-bow, HEZ9VDSB1 90° flat duct bend horizontal, HEZ9VDSB2 90° flat duct L vertical, HEZ9VDSB3 90° flat duct M vertical, HEZ9VDSB4 90° flat duct S vertical, HEZ9VDSI0 Adapter round-flat, HEZ9VDSI1 90° Adapter round-flat, HEZ9VDSM1 Straight tube 500mm, HEZ9VDSM2 Straight tube 1000mm, HEZ9VDSS1 Connector sleeve (female), HEZ9VDSS2 Flex sleeve (female), HEZ9VEDU0 Acoustics Filter, HEZ9VRCR0 cleanAir recirculation replenishment fil, HEZ9VRCR1 Clean Air Plus odor filter (replacement), HEZ9VRPD1 Plinth Diffusor

Product name/family: ..... Cooking zone ceramic  
 Built-in / Free-standing: ..... Built-in  
 Energy type: ..... Electric  
 Min. required niche size for installation (HxWxD): ....223 x 560-560 x 490-490 mm  
 Width of the appliance: ..... 710 mm  
 Dimensions: ..... 223x710x522 mm  
 Dimensions of the packed product (HxWxD): ..... 430 x 940 x 660 mm  
 Net weight: ..... 23.6 kg  
 Gross weight: ..... 30.0 kg  
 Residual heat indicator: ..... Separate  
 Location of control panel: ..... Front  
 Basic surface material: ..... Ceramic  
 Color of surface: ..... Black  
 Length electrical supply cord: ..... 110.0 cm  
 Sealed Burners: ..... No  
 heating with booster: ..... All  
 Power of 2nd heating element (kW): ..... 3.6 kW  
 Number of speed settings: ..... 9-stages + 2 intensive  
 Max. air extraction: ..... 500 m<sup>3</sup>/h  
 Boost position output recirculating: ..... 595.0 m<sup>3</sup>/h  
 Max. air recirculation: ..... 487 m<sup>3</sup>/h  
 Boost position air extraction: ..... 622 m<sup>3</sup>/h  
 Noise level: ..... 69 dB(A) re 1pW  
 Odour filter: ..... No  
 Operating Mode: ..... Convertible  
 Voltage: ..... 220-240/380-415 V  
 Frequency: ..... 50-60 Hz  
 Main colour of product: ..... Black  
 Included accessories: 1 x Slider for unducted recirculation, 1 x Clean Air Plus odor filter



## Series 6, Induction cooktop, 70 cm, surface mount without frame PVQ731F15E

- To complete the fully ducted extraction or to do any other individual recirculation planning additional ducting accessories are required.

### Design

- Bevelled front edge

### Integrated ventilation downdraft system

- Extraction rate according to EN 61591:
- Ducted extraction (Min/Max/Intensive): 154/500/622 m<sup>3</sup>/h
- Recirculated extraction (Min/Max/Intensive): 117/487/595 m<sup>3</sup>/h
- Noise level for ducted extraction (sound power emissions) (Min/Max/Intensive): 42/69/74 dB(A)
- Noise level for recirculated extraction (sound power level) (Min/Max/Intensive): 41/68/72 dB(A)

### Flexibility of cooking zones

- 2 Combi zones
- : use bigger cookware by connecting two classic cooking zones into one large zone.
- Cooking zone front left: 190 mm, 210 mm, 2.2 KW (max. power 3.7 KW)
- Cooking zone rear left: 190 mm, 210 mm, 2.2 KW (max. power 3.7 KW)
- Cooking zone rear right: 190 mm, 210 mm, 2.2 KW (max power 3.7 KW)
- Cooking zone front right: 190 mm, 210 mm, 2.2 KW (max. power 3.7 KW)

### Comfort & Convenience

- TouchControl MultiTouch: effortlessly change the power with the imprinted touch bar.
- 17 power levels: precisely adapt the heat with 17 power levels (9 main levels and 8 intermediate levels).
- Timer with automatic switch off for all zones: switches off the cooking zone at the end of the time set (e.g. for boiled eggs).
- Alarm clock
- : an alarm sounds at the end of the time set (e.g. for pasta).

### Time saving & Efficiency

- PowerBoost: rapid heating for large pots of water, automatically turns off right on time to prevent overheating
- : boil water more quickly thanks to 50% more energy than at the highest standard level.
- Move function: increase or decrease the power level simply by moving the pot forwards or backwards.
- QuickStart: Quick and automatic first pot detection: when switching on, the cooktop automatically selects the cooking zone with cookware (placed in off-mode).
- ReStart function: in case of unintentional switch-off, restore all previous settings by switching on the cooktop again within 4 seconds.

### Safety

- Digital 2 stage residual heat indicator: indicates which cooking zones are still hot or warm.
- Childproof lock: prevent unintended activation of the cooktop.
- WipeProtection, Childproof lock, PowerManagement Function, Automatic pan recognition sensor, Automatic Safety switch-off:

wipe overboiled liquids without unintentionally changing settings (blocking all touch buttons for 30 seconds).

- Main switch: switch off all cooking zones at the touch of a button.
- Automatic Safety switch-off: for safety reasons, heating stops after a preset time without interaction.
- Energy consumption: shows the electricity consumption of the last cooking process.

### Installation

- Dimensions of the product (HxWxD mm): 223 x 710 x 522
- Required niche size for installation (HxWxD mm) : 223 x 560 x (490 - 490)
- Min. worktop thickness: 16 mm
- Connected load: 7.4 KW
- PowerManagement Function: limit the maximum power if needed (depends on fuse protection of electric installation).

## Series 6, Induction cooktop, 70 cm, surface mount without frame PVQ731F15E

measurements in mm

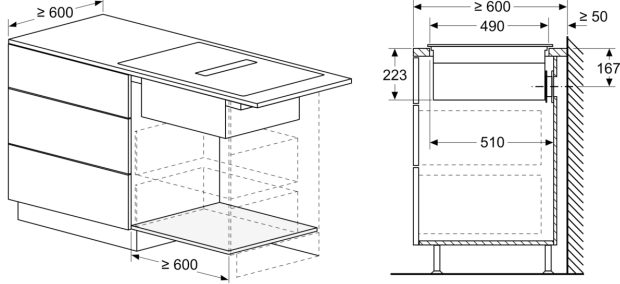

Measurements in mm

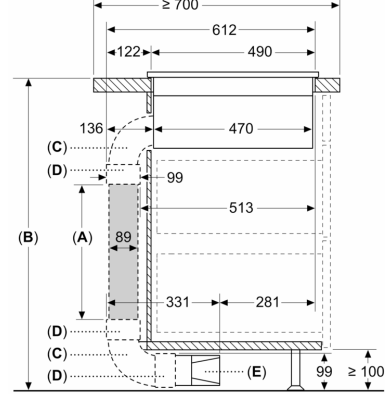

**A:** Tube length  
**B:** Kitchen height  
**C:** 90° L-size bow  
**D:** Connector sleeve  
**E:** Diffusor

Ducting kit available for  $\geq 700$  mm depth worktops and up to 960 mm height

The installer has to select the tube length and if necessary cut it according to the kitchen height

A	B
500	$\leq 960$
1000	$> 960$

Measurements in mm

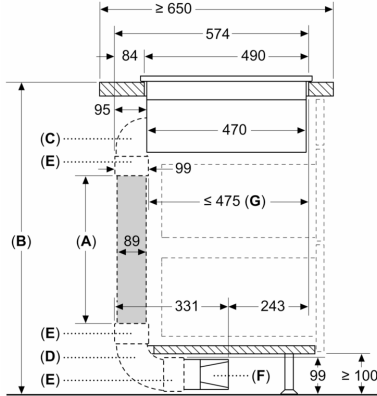

**A:** Tube length  
**B:** Kitchen height  
**C:** 90° M-size bow  
**D:** 90° L-size bow  
**E:** Connector sleeve  
**F:** Diffusor  
**G:** Shortened Drawer

The installer has to select the tube length and if necessary cut it according to the kitchen height

A	B
500	$\leq 940$
1000	$> 940$

Measurements in mm

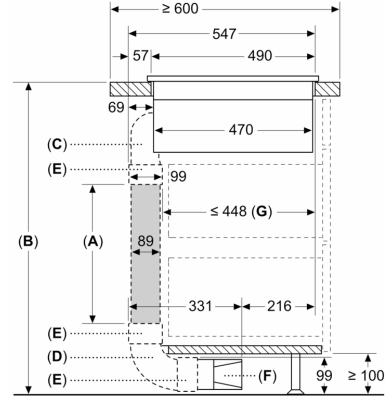

**A:** Tube length  
**B:** Kitchen height  
**C:** 90° S-size bow  
**D:** 90° L-size bow  
**E:** Connector sleeve  
**F:** Diffusor  
**G:** Shortened Drawer

Ducting kit available for  $\geq 600$  mm depth worktops and up to 960 mm height

The installer has to select the tube length and if necessary cut it according to the kitchen height

A	B
500	$\leq 990$
1000	$> 990$

measurements in mm

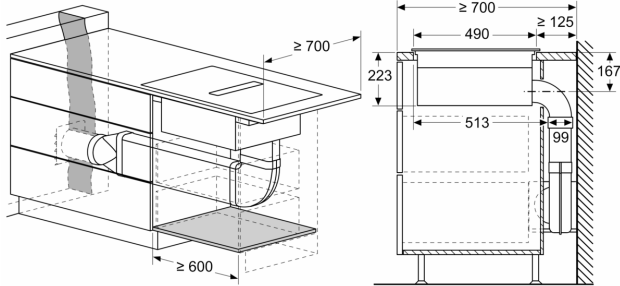

measurements in mm

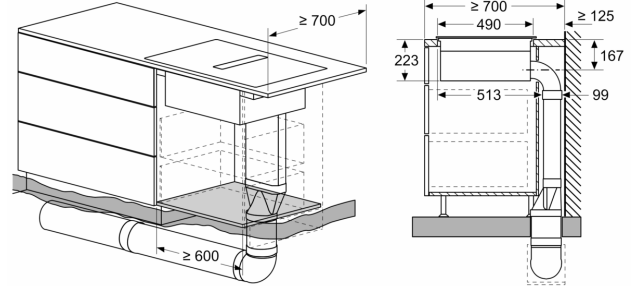

measurements in mm

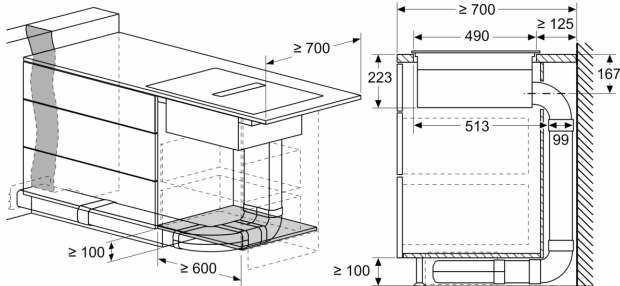

measurements in mm

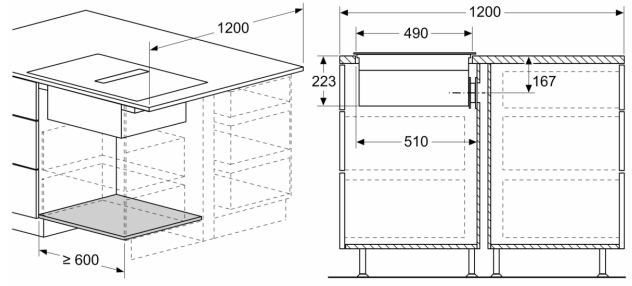

measurements in mm

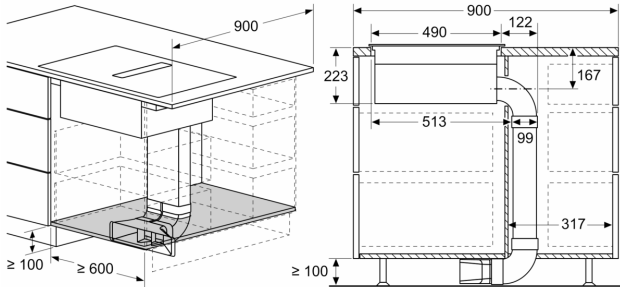

Measurements in mm

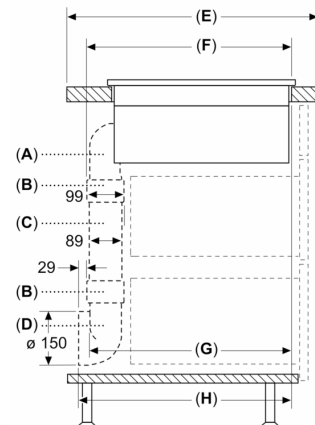

A	E	F	G	H
S-size	≥ 600	547	545	579
M-size	≥ 650	574	569	603
L-size	≥ 700	612	609	643

**A:** 90° Bow  
**B:** Connector sleeve  
**C:** Straight tube  
**D:** 90° Adapter round-flat

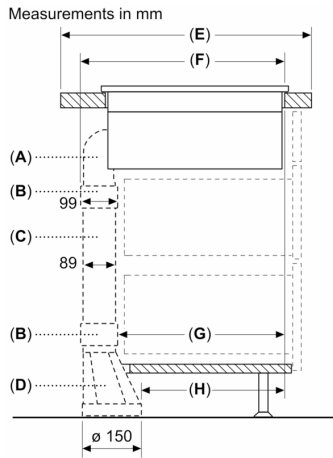

A	E	F	G	H
S-size	≥ 600	547	451	389
M-size	≥ 650	574	475	413
L-size	≥ 700	612	515	453

- A: 90° Bow
- B: Connector sleeve
- C: Straight tube
- D: Straight adapter round-flat

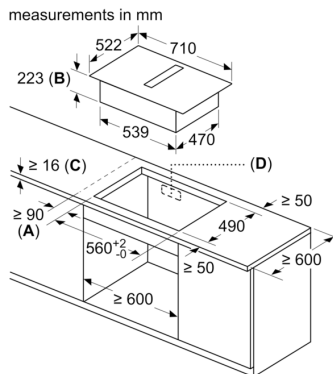

- A: Minimum distance from the hob cut-out to the wall
- B: Recessing depth
- C: The worktop into which the hob is installed must withstand loads of approx. 60kg; suitable substructures must be used if required.
- D: Cut-out in back panel required for pipework. Exact size and position can be taken from specific drawing.

Measurements in mm

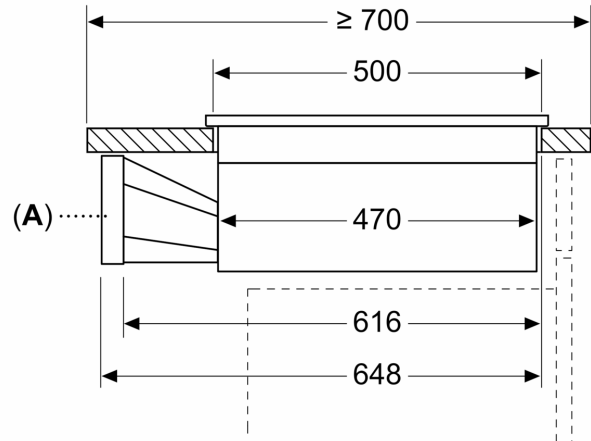

A: Adapter round-flat

measurements in mm  
Front view

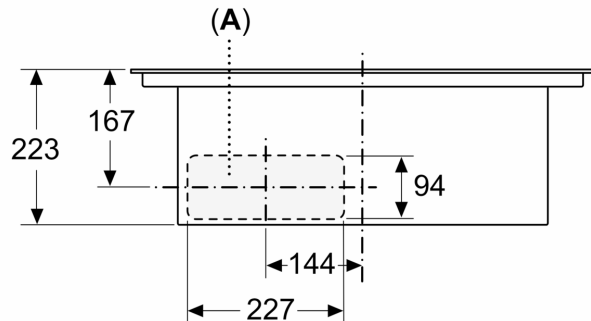

A: Connected directly at the rear

measurements in mm  
 Front view - unit cut-out  
 for unducted recirculation

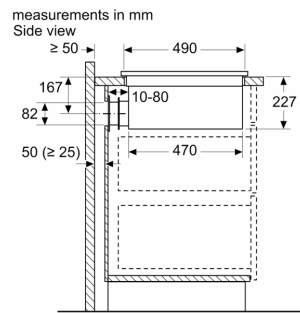
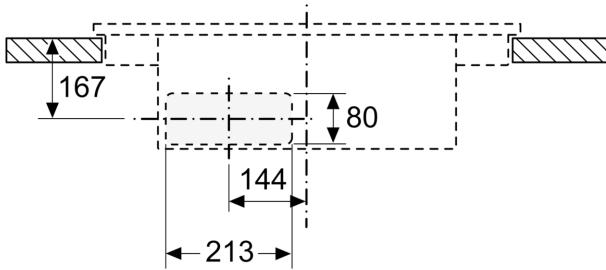

When installing directly against outer walls that are not insulated ( $\mu \geq 0.5 \text{ W/m}^2\text{-}^\circ\text{C}$ ), we recommend using partially or fully ducted recirculation configurations.

measurements in mm  
 Front view

