

Series 8, Front Load Washing Machine, 10 kg, 1600 rpm WAX32M40SG



Remove common stains quickly and easily with Bosch Anti-Stain technology for greater peace of mind everytime.

- **AntiStain:** reliably removes up to 4 most common stains (blood, butter/oil, grass, red wine).
- **4D Wash System:** highly efficient water and detergent fabric penetration for spotless results.
- **Eco Silence Drive™:** the efficient and highly durable washing machine drive.
- **Anti Vibration™ Design:** extremely stable and especially quiet thanks to special vibration protection.
- **Intensive Plus:** for extra cleaning boost for heavily soiled and full loads.

- WMZ2200 Floor securing component
- WMZ2381 Extension for cold water inlet /Aquastop
- WMZPW20W Platform with pull-out, washer, cubic

Built-in / Free-standing:	Free-standing
Door hinge:	Left
Color / Material body:	White
Length electrical supply cord:	210.0 cm
Height of the appliance:	848 mm
Dimensions of the product:	848x598x590 mm
Wheels:	No
Net weight:	82.4 kg
Drum volume:	70 l
Door Frame:	Chrome, blackgray
Noise level washing:	49 dB(A) re 1pW
Connection rating:	2300 W
Fuse protection:	10 A
Voltage:	220-240 V
Frequency:	50 Hz
Energy Star Qualified:	No
Cord Included:	Yes
Plug type:	GB plug
Length of supply hose (in):	59.05 "
Dimensions of the packed product:	34.44 x 25.19 x 26.57
Net weight:	182.000 lbs
Gross weight:	183.000 lbs
Length of drain hose:	150.00 cm
Length of supply hose:	150.00 cm
Dimensions of the packed product (HxWxD):	875 x 640 x 675 mm
Gross weight:	83.2 kg
Connection rating:	2300 W
Fuse protection:	10 A
Voltage:	220-240 V
Frequency:	50 Hz
Water protection system:	Aquastop
Max. spin speed:	1600 rpm
Spin speed options:	Variable
Digital countdown indicator:	Yes
Progress indicator:	LED-display
Capacity:	10.0 kg



Series 8, Front Load Washing Machine, 10 kg, 1600 rpm WAX32M40SG

**Remove common stains quickly and easily
with Bosch Anti-Stain technology for
greater peace of mind everytime.**

Technical Information

- Capacity: 10kg
- Maximum spin speed : 1600 rpm
- Dimensions (H x W x D): 84.8cm x 59.8 cm x 59.0 cm
- 32 cm porthole, 171° swing

Programmes

- Cottons, Cottons Eco, Synthetics, Daily Wash, Delicates/Silk, Wool, Rinse, Spin/Drain, Drum Clean, Duvet, Shirts/Blouses, Super Quick 15'/30", AllergyPlus, ExpressClean 59'
- Clean your laundry in just 59minutes with ExpressClean 59'
- AllergyPlus effectively reduces allergenic residue such as pollen, animal hair, and dust mites at the touch of a button and is suitable for those with sensitive, irritable skin
- Time delay to select end of time of your wash (1-24 hours) and time remaining indicator
- Start/Reload function to pause machine operation for adding in last minute laundry items

Features

- Clean your laundry in just 59minutes with PowerMix was programme with 4D wash system
- EcoSilence Drive™ friction-free motor minimises heat and wear for long-lasting performance, quiet operation and perfect wash results.
- AntiStain: Automatic stain removal of the most common stains
- ActiveWater™ Plus: Pressure and water sensor that measures the washing load and adjusts water intake to 256 precise levels for more cost and water savings
- VarioDrum's breakthrough wave-droplet design provides a thorough yet gentle clean for fine textiles
- Anti-Vibration Side Panels reduce vibrations and ensure greater stability during the washing and spinning process.
- Child-proof lock

Safety

- AquaStop™ anti-flood protection system with magnetic valve and float switch
- Child-proof lock

Display Screen & Alerts

- Large LED display screen to indicate: Programme status, Temperature and Spin Speed Selection, Remaining Time and 24 Hour End Time Delay, Load Recommendation and Consumption

**Series 8, Front Load Washing
Machine, 10 kg, 1600 rpm
WAX32M40SG**

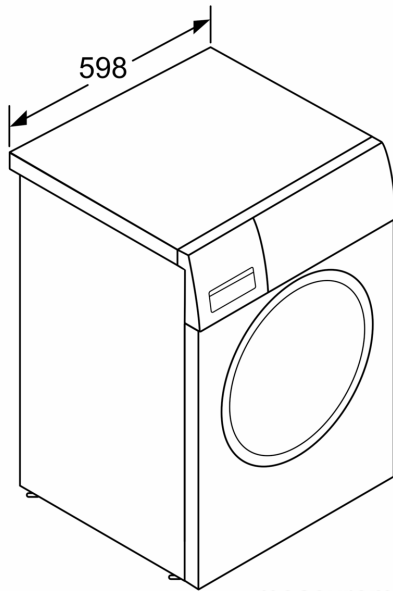

measurements in mm