

**Series 4, Built-in Microwave Oven,
60 x 38 cm, Stainless steel
BFL523MS0B**



1 x Turntable

HEZ86D000 Steamer Cooker Accessory for Microwave

**The built-in microwave for the 38 cm
niche: use it for thawing, heating and
faster preparation of foods.**

- **Microwave function:** time saving preparation, defrosting and re-heating of dishes.
- **AutoPilot 7:** every dish is a perfect success thanks to 7 pre-set automatic programmes.
- **LED display control, red:** easy-to-use thanks to the time functions.
- **pop-out controls:** for an easy to clean front.
- **Cleaning Assistance:** less cleaning effort thanks to the new cleaning option, which can be especially used for cleaning of light soiling.

Additional function: Microwave only
 Type of control: Electronic
 Dimensions (HxWxD): 382x594x317 mm
 Cavity dimensions: 201.0 x 308.0 x 282.0 mm
 Length electrical supply cord: 130.0 cm
 Net weight: 15.3 kg
 Gross weight: 17.6 kg
 Max. microwave power level: 800 W
 Number of power levels: 5
 Turntable: Yes
 Cavity material: Stainless steel
 Door opening: Button
 Clock: Yes
 Included accessories: 1 x Turntable
 Height of the appliance: 382 mm
 Width of the appliance: 594 mm
 Depth of the product: 317 mm
 Max. microwave power level: 800 W
 Connection rating: 1270 W
 Fuse protection: 10 A
 Voltage: 230-240 V
 Frequency: 50 Hz
 Plug type: GB plug
 Required cutout/niche size for installation (in): x
 Dimensions of the packed product: 17.32 x 14.96 x 25.98
 Net weight: 34.000 lbs
 Gross weight: 39.000 lbs



Series 4, Built-in Microwave Oven, 60 x 38 cm, Stainless steel BFL523MS0B

**The built-in microwave for the 38 cm
niche: use it for thawing, heating and
faster preparation of foods.**

Microwave and heating mode:

- Max. Power: 800 W; 5 Microwave power settings: 90 W, 180 W, 360 W, 600 W, 800 W
- Cavity volume: 20 l

Design

- stainless steel cavity

Comfort

- LED
- electronic clock
- Rotary Control, Retractable rotary knobs, Touch control, Round, Start button
- User-friendly electronics: extremely
- easy and comfortable operation
- AutoPilot 7
- 4 defrost and 3 cooking programmes in microwave function
- Memory function (1 setting)
- LED light
- 25.5 cm Glass
- side opening door, hinge left
- Open Button, electric
- Touch key operation

Accessories

- 1 x Turntable

Environment and Safety

- Automatic switch off
- Door contact switch
- Integral cooling fan
- Length of mains cable: 130 cm
- Electrical connection rating: 1270 W
- Nominal voltage: 230 - 240 V
- Suitable for tall housing installation, Can be built in a 60 cm wall cupboard (at least 30cm deep)

Dimensions:

- Dimensions of the product (HxWxD mm) : 382 x 594 x 317
- Niche dimension (HxWxD): 362 mm - 365 mm x 560 mm - 568 mm x 300 mm
- "Please refer to the built-in dimensions provided in the installation drawing"

**Series 4, Built-in Microwave Oven,
60 x 38 cm, Stainless steel
BFL523MS0B**

Microwave,
corner installation

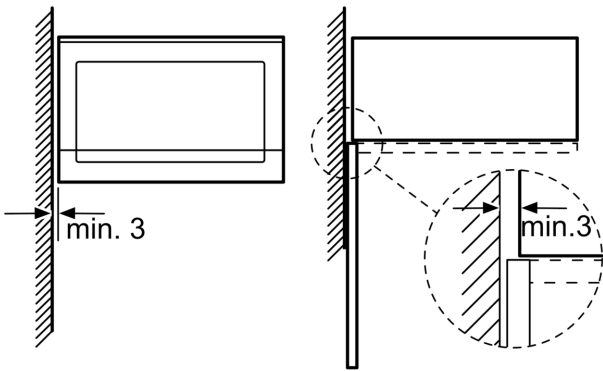

Measurements in mm

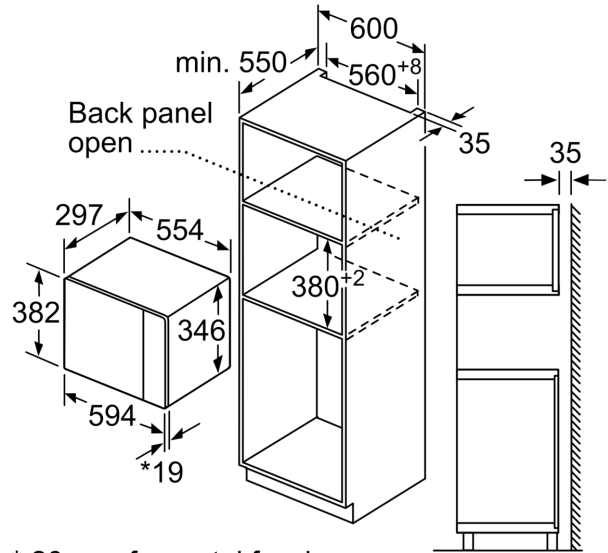

* 20 mm for metal fascia

measurements in mm

Measurements in mm

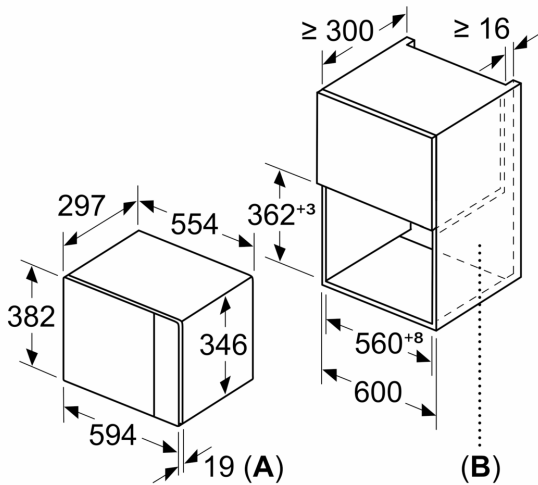

A: 20 mm for metal fascia
B: Back panel open

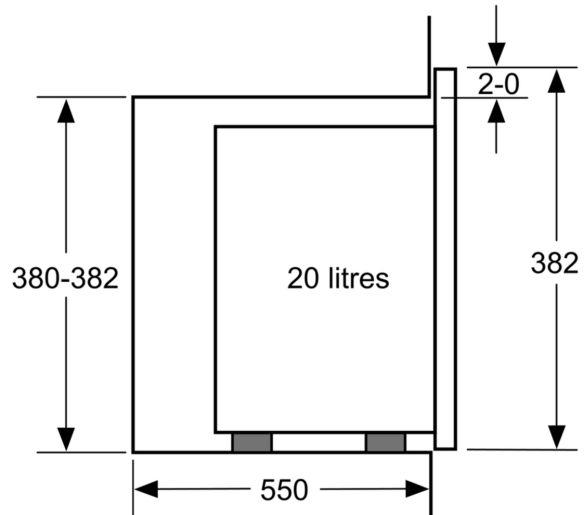

measurements in mm

