

**Series 8, washing machine,  
frontloader fullsize, 9 kg, ,  
WAW3256XGC**



WMZ2200 Floor securing component  
WMZ2381 Extension for cold water inlet /Aquastop

**The washing machine with new design and  
EcoSilence Drive™: enjoy supremely quiet  
operation and excellent durability.**

- **AntiVibration™ Design:** extremely stable and especially quiet thanks to special vibration protection.
- **AntiStain:** reliably removes up to 4 most common stains (blood, butter/oil, grass, red wine).
- **AllergyPlus:** specially developed for the needs of allergy sufferers and sensitive skin.
- **SpeedPerfect:** perfectly clean in up to 65% less time.
- **ComfortControl with consumption indication:** easy operation and indication of energy and water consumption.

Built-in / Free-standing: ..... Free-standing  
Door hinge: ..... Left  
Color / Material body: ..... Inox-easyclean  
Length electrical supply cord: ..... 160.0 cm  
Height of the appliance: ..... 848 mm  
Dimensions of the product: ..... 848 x 598 x 590 mm  
Wheels: ..... No  
Net weight: ..... 79.2 kg  
Drum volume: ..... 60 l  
Door Frame: ..... Chrome, blackgray  
Color Buttons: ..... chrome, black, silver inox  
Color Dial: ..... chrome  
Noise level washing: ..... 48 dB(A) re 1 pW  
Connection rating: ..... 2300 W  
Fuse protection: ..... 10 A  
Voltage: ..... 220-240 V  
Frequency: ..... 50 Hz  
Energy Star Qualified: ..... Yes  
Cord included: ..... Yes  
Plug type: ..... GB plug  
Length of supply hose (in): ..... 59.05 "  
Dimensions of the packed product: ..... 34.25 x 25.19 x 26.77  
Net weight: ..... 175.000 lbs  
Gross weight: ..... 176.000 lbs  
Length of drain hose: ..... 150.00 cm  
Length of supply hose: ..... 150.00 cm  
Dimensions of the packed product (HxWxD): ..... 870 x 640 x 680 mm  
Gross weight: ..... 80.0 kg  
Connection rating: ..... 2300 W  
Fuse protection: ..... 10 A  
Voltage: ..... 220-240 V  
Frequency: ..... 50 Hz  
Water protection system: ..... Multiple water protection  
Maximum spin speed: ..... 1600 rpm  
Spin speed options: ..... Variable  
Digital countdown indicator: ..... Yes  
Progress indicator: ..... LED-display  
Maximum capacity in kg (EU 2017/1369): ..... 9.0 kg



## Series 8, washing machine, frontloader fullsize, 9 kg, , WAW3256XGC

**The washing machine with new design and  
EcoSilence Drive™: enjoy supremely quiet  
operation and excellent durability.**

### Technical Information

- Dimensions (H x W x D): 84.8 cm x 59.8 cm x 59.0 cm
- Slide-under height of 85cm

### engine power and consumption

- rated capacity: 9 kg
- spin-drying efficiency class: A
- max.spin speed 1600
- Duration of the left-on mode: 0 min
- Noise level washing in standard 60° cotton programme at full load in dB (A) re 1 pW: 48
- Noise level spinning at standard 60°C cotton programme at full loading in dB (A) re 1 pW: 74

### Programmes

- Special programmes: allergy plus, drain, Drum Clean (with reminder), quick 15', shirts/blouses, night wash, Family Mix, sportswear, rinsing/spinning, Duvet, delicate/silk, wool / hand wash

### options

- VarioPerfect: time- or energy optimized programs with perfect wash performance
- TouchControl buttons: Easy Iron, EcoPerfect, On/off, end time delay, stain selection, SpeedPerfect, start/pause, Temperature, Prewash, Aqua plus, Spin speed selection and 24 h end time delay
- Stain automatic – 4 stain removal options at the touch of a button

### comfort and safety

- XXL Drum volume: 60 l
- VarioDrum: gentle and efficient washing
- DrumClean with reminder function
- 32 cm porthole, chrome, blackgrey with 171° opening door
- comfort lock
- Reload function / pause function
- EcoSilence Drive: quiet motor with long lifetime
- AntiVibration Design: more stability and quietness
- Sound insulation by bottom cover
- Flow sensor for optimal wateruse
- ActiveWater™Plus: resource gentle watermanagement
- Multiple water protection
- Consumption Indication: Information about energy and water consumption
- control dial with integrated On-/Offmode
- Large LED-Display for programme status indication, temperature selection, max. spin speed, remaining time and 24 h end time delay, stain selection and consumption indication
- Foam detection system to remove excessive foam
- Unbalanced load detection
- Child-proof lock
- Buzzer at the end of the programme
- Continuous automatic load adjustment system
- Easy cleaning detergent drawer
- Divider for Liquid Detergent

**Series 8, washing machine,  
frontloader fullsize, 9 kg, ,  
WAW3256XGC**

---

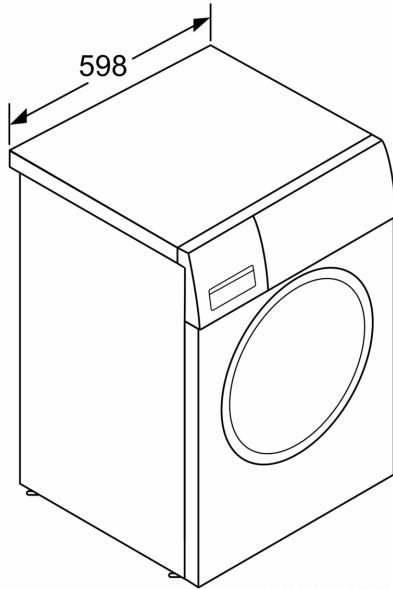

measurements in mm