

**Series 6, washing machine, front loader, 10 kg, Silver inox WGA254AVIN**



WMZ2200 Floor securing component  
 WMZ2381 Extension for cold water inlet /Aquastop

**Minimize wrinkles by up to 50%**

- **i-DOS:** automatically measures the precise amount of detergent and water needed.
- **Anti Wrinkle feature** minimizes wrinkles in laundry by up to 50% making it gentler on fabric and easier to iron
- **EcoSilence Drive™:** extremely energy-efficient and quiet in operation with a 10-year warranty.
- **SpeedPerfect:** perfectly clean in up to 65% less time\*.
- **Vario Drum:** gently and efficiently wash with even water distribution and without creasing garments.
- **EcoSilence Drive™ friction-free motor** minimises heat and wear for long-lasting performance, quiet operation and perfect wash results.

Built-in / Free-standing: ..... Freestanding  
 Door hinge: ..... left  
 Color / Material body: ..... Silver inox  
 Length electrical supply cord: ..... 160.0 cm  
 Height of the appliance: ..... 845 mm  
 Dimensions of the product: ..... 845 x 597 x 588 mm  
 Wheels: ..... No  
 Net weight: ..... 67.0 kg  
 Drum volume: ..... 68 l  
 Noise level washing: ..... 49 dB(A) re 1 pW  
 Connection rating: ..... 2300 W  
 Fuse protection: ..... 10 A  
 Voltage: ..... 220-240 V  
 Frequency: ..... 50 Hz  
 Energy Star Qualified: ..... No  
 Cord Included: ..... Yes  
 Plug type: ..... India plug (10 Ampere)  
 Length of supply hose (in): ..... 59.05 "  
 Dimensions of the packed product: ..... 34.25 x 25.19 x 26.37  
 Net weight: ..... 148.000 lbs  
 Gross weight: ..... 149.000 lbs  
 Length of drain hose: ..... 150.00 cm  
 Length of supply hose: ..... 150.00 cm  
 Dimensions of the packed product (HxWxD): ..... 870 x 640 x 670 mm  
 Gross weight: ..... 67.8 kg  
 Connection rating: ..... 2300 W  
 Fuse protection: ..... 10 A  
 Voltage: ..... 220-240 V  
 Frequency: ..... 50 Hz  
 Water protection system: ..... Multiple water protection  
 Max. spin speed: ..... 1400 rpm  
 Spin speed options: ..... Variable  
 Digital countdown indicator: ..... Yes  
 Drying progress indicator: ..... LED-display, LED  
 Maximum capacity in kg (EU 2017/1369): ..... 10.0 kg



## **Series 6, washing machine, front loader, 10 kg, , Silver inox WGA254AVIN**

### **Minimize wrinkles by up to 50%**

---

#### **Technical Information**

- Capacity: 10kg
- Maximum spin speed: 1400 rpm
- Dimensions (H x W x D): 84.8 cm x 59.7 cm x 58.8 cm (63.2cm with door frame)
- 32cm, pothole 160° swing door

#### **Programmes**

- Cottons, Cottons 60°C Label, Cottons Eco, Synthetics, Wool, Quick 15/30min, Mix Load, Rinse, Spin/Drain, Drum Clean, Delicates/Silk, Quilt/Blanket, AllergyPlus, Automatic 40°C

#### **Features**

- Anti Wrinkle feature minimizes wrinkles in laundry by up to 50% making it gentler on fabric and easier to iron
- SpeedPerfect™: high performance programme which reduces wash cycle duration by up to 65%
- ActiveWater™ Plus: Pressure and water sensor that measures the washing load and adjusts water intake to 256 precise levels for more cost and water savings
- VarioDrum's breakthrough wave-droplet design provides a thorough yet gentle clean for fine textiles
- AllergyPlus programme - suitable for allergy sufferers.
- Anti-Vibration Side Panels reduce vibrations and ensure greater stability during the washing and spinning process.
- Reload function to pause machine operation for adding in last minute laundry items
- Time delay to select end of time of your wash (1-24 hours) and time remaining indicator
- Foam detection system to remove excessive foam

#### **Safety**

- Voltmonitor - monitors, regulates and feedback voltage fluctuations to manage unstable electrical supply to protect the washing machine and ensure a smooth wash cycle
- Multiple water protection with magnetic valve to minimise risk of leakage

#### **Display Screen & Alerts**

- Large LED display screen to indicate: Programme status, Temperature and Spin Speed Selection, Remaining Time and 24 Hour End Time Delay, Load Recommendation and Energy Consumption
- TouchControl buttons: Start/Reload, Temperature, speedPerfect, Rinse Plus, Spin Speed Reduction

**Series 6, washing machine, front loader, 10 kg, Silver inox WGA254AVIN**

Measurements in mm

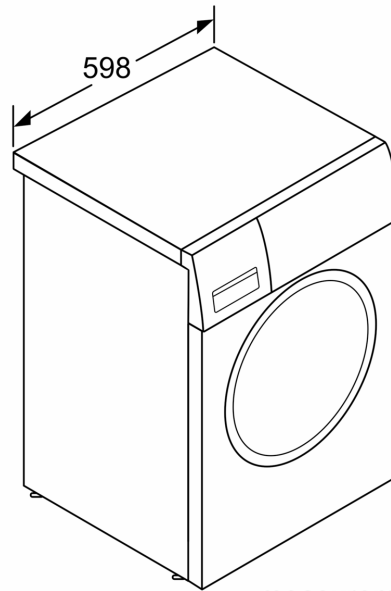
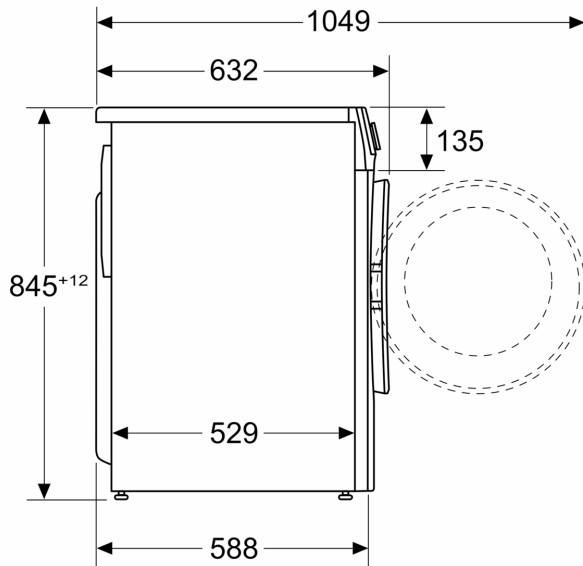

measurements in mm