

Series 8, washing machine, front loader, 9 kg, , Silver inox WGA2440XIN



- The AntiStain option easily removes the up to 4 of the most stubborn stains, ranging from oil, tea, cosmetics and blood helping you get the perfect washing results, easily.
- Anti Wrinkle feature minimizes wrinkles in laundry by up to 50% making it gentler on fabric and easier to iron
- Anti Stain Plus: removes up to 16 kinds of stubborn stains without pre-treatment.
- Eco Silence Drive™: the efficient and highly durable washing machine drive.
- Allergy Plus: developed for allergy sufferers and people with sensitive skin.

Built-in / Free-standing: Freestanding
 Door hinge: left
 Color / Material body: Silver inox
 Length electrical supply cord: 160.0 cm
 Height of the appliance: 848 mm
 Dimensions of the product: 848x598x588 mm
 Wheels: No
 Net weight: 72.2 kg
 Drum volume: 65 l
 Door Frame: Silver-inox, black-grey
 Noise level washing: 54 dB(A) re 1pW
 Connection rating: 2300 W
 Fuse protection: 10 A
 Voltage: 220 V
 Frequency: 50 Hz
 Energy Star Qualified: Yes
 Cord Included: Yes
 Plug type: India plug (10 Ampere)
 Length of supply hose (in): 59.05 "
 Dimensions of the packed product: 34.25 x 25.59 x 26.77
 Net weight: 159.000 lbs
 Gross weight: 161.000 lbs
 Length of drain hose: 150.00 cm
 Length of supply hose: 150.00 cm
 Dimensions of the packed product (HxWxD): 870 x 650 x 680 mm
 Gross weight: 73.0 kg
 Connection rating: 2300 W
 Fuse protection: 10 A
 Voltage: 220 V
 Frequency: 50 Hz
 Water protection system: Multiple water protection
 Max. spin speed: 1400 rpm
 Spin speed options: Variable
 Digital countdown indicator: Yes
 Drying progress indicator: LED-display, LED
 Maximum capacity in kg (EU 2017/1369): 9.0 kg

WMZ2200 Floor securing component
 WMZ2381 Extension for cold water inlet /Aquastop



Series 8, washing machine, front loader, 9 kg, , Silver inox WGA2440XIN

- WGA2440XIN
- Ferrite-BLDC

Design

- rated capacity: 9 kg
- energy consumption of the standard 60 °C cotton programme 0.99 kwh at full load and 0.81 kwh at partial load and of the standard 40 °C cotton programme 0.69 kwh at partial load
- Special programmes: Synthetics, Hygiene, Delicate/Silk, Mix, Wool (Gentle handwash), Cottons
- Mix load
- LED programme progress indicators
- Touch control buttons
- Consumption: energy 0.98 kwh, water 55 l
- Maximum Spin Speed: 1400 rpm
- Display for programme progress indication, temperature, spin speed, remaining time and 24 h end time delay
- Foam detection system
- Noise level washing: 54 dB; Noise level spinning: 72 dB
- Noise level spinning: 72dB (A) re 1 pW:

Programmes

- Programmes: Synthetics, Hygiene, Delicate/Silk, Daily wash, Wool, Cottons

Performance

- EcoPerfect
- touchControl buttons: Start/Reload, Easy iron, Spin speed reduction/Rinse Hold

Key features

- waveDrum
- Multiple Water Protection
- Large display for programme progress indication, temperature, spin speed, remaining time, 24 h end time delay and load recommendation
- Fully electronic control dial for all wash- and special programs
- AntiVibration Design: more stability and quiet
- Prewash
- ActiveWater
- Load recommendation
- Foam detection system to remove excessive foam
- Unbalanced load detection
- Pre-activated SpeedPerfect
- voltMonitor
- Child-proof lock
- Monsoon Programme
- Time delay to select end of time of your wash (1-24 hours) and time remaining indicator
- Reload Function

Technical Information

- Dimensions (H X W X D): 84.8 x 59.8 x 58.8 cm
- Noise level washing: 54 dB; Noise level spinning: 74 dB

**Series 8, washing machine, front
loader, 9 kg, , Silver inox
WGA2440XIN**

Measurements in mm

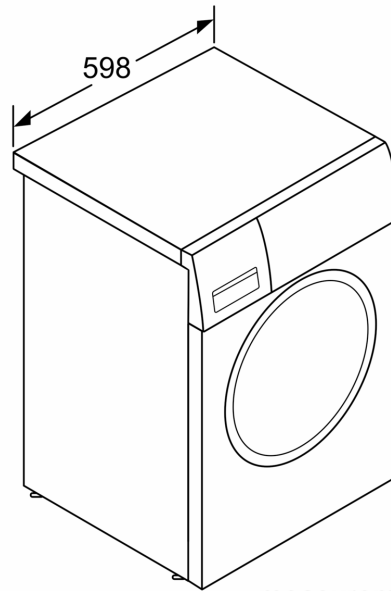

measurements in mm