

**Series 8, washing machine, front loader, 9 kg, 1400 rpm
WGA24400IN**



Built-in / Free-standing: Freestanding
 Door hinge: left
 Color / Material body: White
 Length electrical supply cord: 160.0 cm
 Height of the appliance: 848 mm
 Dimensions of the product: 848x598x588 mm
 Wheels: No
 Net weight: 72.1 kg
 Drum volume: 65 l
 Door Frame: Silver-inox, black-grey
 Noise level washing: 54 dB(A) re 1pW
 Connection rating: 2300 W
 Fuse protection: 10 A
 Voltage: 220 V
 Frequency: 50 Hz
 Energy Star Qualified: Yes
 Cord Included: Yes
 Plug type: India plug (10 Ampere)
 Length of supply hose (in): 59.05 "
 Dimensions of the packed product: 34.25 x 25.59 x 26.77
 Net weight: 159.000 lbs
 Gross weight: 161.000 lbs
 Length of drain hose: 150.00 cm
 Length of supply hose: 150.00 cm
 Dimensions of the packed product (HxWxD): 870 x 650 x 680 mm
 Gross weight: 73.1 kg
 Connection rating: 2300 W
 Fuse protection: 10 A
 Voltage: 220 V
 Frequency: 50 Hz
 Water protection system: Multiple water protection
 Max. spin speed: 1400 rpm
 Spin speed options: Variable
 Digital countdown indicator: Yes
 Drying progress indicator: LED-display, LED
 Maximum capacity in kg (EU 2017/1369): 9.0 kg

WMZ2200 Floor securing component
 WMZ2381 Extension for cold water inlet /Aquastop



**Series 8, washing machine, front
loader, 9 kg, 1400 rpm
WGA24400IN**

Measurements in mm

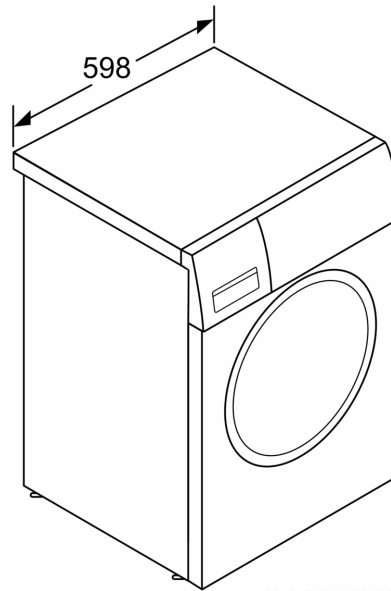
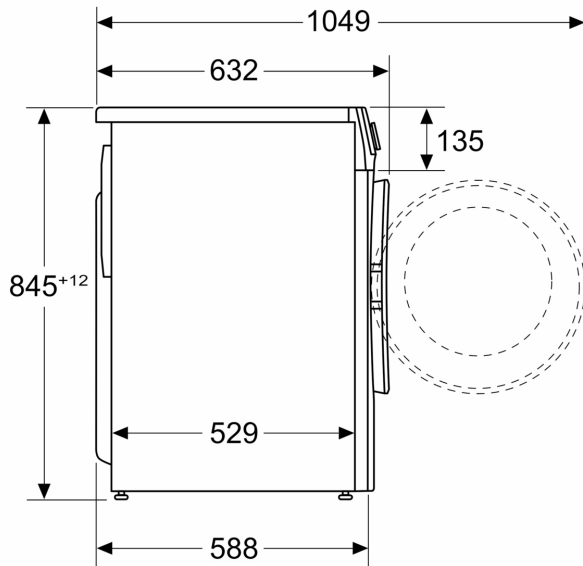

measurements in mm