

Series 2, washing machine, front loader, 6 kg, , Silver inox WAB20267IN



- WMZ20490 Platform with pull-out
- WMZ2200 Floor securing component
- WMZ2381 Extension for cold water inlet /Aquastop

SpeedWash: Optimal washing results in lesser laundry time

- **Allergy Plus:** developed for allergy sufferers and people with sensitive skin.
- **VarioPerfect™:** takes up to 65% less time or uses up to 50% less energy – by simply selecting SpeedPerfect or EcoPerfect functions.
- **1-7 kg load:** wash up to 7 kg of laundry.
- **Super Quick 30 is a convenient method of freshening up light-solied laundry in 30 minutes**
- **VoltCheck: feedback to users in case of unstable electricity supply**

Built-in / Free-standing: Freestanding
 Door hinge: left
 Color / Material body: Silver inox
 Length electrical supply cord: 160.0 cm
 Height of the appliance: 850 mm
 Dimensions of the product:850 x 600 x 560 mm
 Wheels:No
 Net weight: 72.3 kg
 Drum volume: 42 l
 Door Frame: Silver inox
 Color Buttons: silver inox
 Color Dial:silver inox
 Noise level washing: 57 dB(A) re 1 pW
 Connection rating: 2300 W
 Fuse protection:10 A
 Voltage: 220-240 V
 Frequency: 50 Hz
 Energy Star Qualified:No
 Cord Included:No
 Plug type: India plug (10 Ampere)
 Length of supply hose (in):59.05 "
 Dimensions of the packed product: 34.44 x 25.39 x 26.18
 Net weight: 159.000 lbs
 Gross weight: 168.000 lbs
 Length of drain hose: 125.00 cm
 Length of supply hose: 150.00 cm
 Dimensions of the packed product (HxWxD): 875 x 665 x 645 mm
 Gross weight: 76.2 kg
 Connection rating: 2300 W
 Fuse protection:10 A
 Voltage: 220-240 V
 Frequency: 50 Hz
 Water protection system:Multiple water protection
 Max. spin speed: 1000 rpm
 Spin speed options: Variable
 Digital countdown indicator: Yes
 Drying progress indicator: LED
 Maximum capacity in kg (EU 2017/1369): 6.0 kg



Series 2, washing machine, front loader, 6 kg, , Silver inox WAB20267IN

SpeedWash: Optimal washing results in lesser laundry time

Design

- rated capacity: 6 kg
- energy consumption of the standard 60 °C cotton programme 0.99 kwh at full load and 0.81 kwh at partial load and of the standard 40 °C cotton programme 0.69 kwh at partial load
- Special programmes: Synthetics, Hygiene, Delicate/Silk, Mix, Wool (Gentle handwash), Cottons
- Mix load
- LED programme progress indicators
- Touch control buttons
- Consumption: energy 0.98 kwh, water 55 l
- Maximum Spin Speed: 1000 rpm
- Display for programme progress indication, temperature, spin speed, remaining time and 24 h end time delay
- Foam detection system
- Noise level washing: 57 dB; Noise level spinning: 73 dB
- Noise level spinning: 73dB (A) re 1 pW:
- Noise level washing: 54 dB; Noise level spinning: 74 dB

Programmes

- Programmes: Synthetics, Hygiene, Delicate/Silk, Daily wash, Wool, Cottons

Performance

- EcoPerfect
- Buttons: Spin Speed Selection, EcoPerfect, SpeedPerfect, Ready In, Temperature

Key features

- Drum volume: 42 l
- Multiple Water Protection
- Large LED display
- Fully electronic control dial for all wash- and special programs
- Prewash
- ActiveWater
- Foam detection system to remove excessive foam
- Unbalanced load detection
- voltMonitor
- Monsoon Programme
- Child-proof lock
- Easy ironing
- autoLoad
- Inlay display

Technical Information

- Dimensions (H X W X D): 85 x 60 x 56 cm

**Series 2, washing machine, front loader, 6 kg, , Silver inox
WAB20267IN**

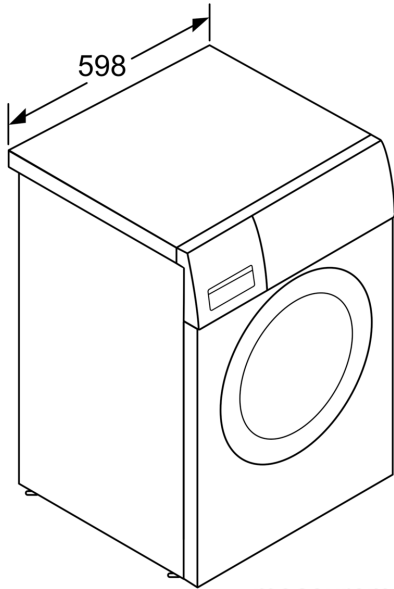

measurements in mm

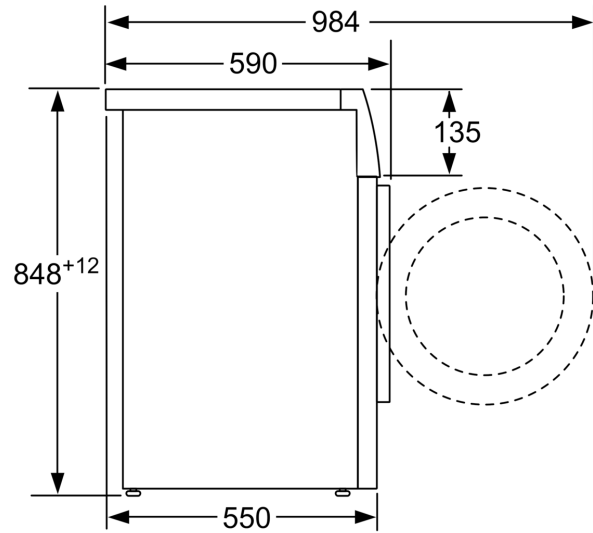

measurements in mm