

## Series 6, Gas hob, 90 cm, Tempered glass, Black PPQ9B6O90I

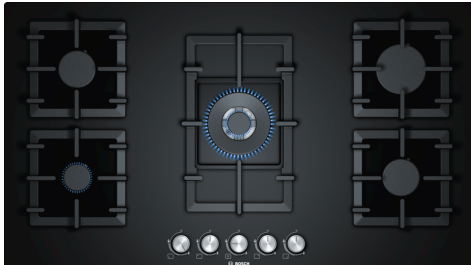

- 6mm Tempered Glass
- Dual-flame power burner has two rings for low and high flame settings to go from simmer to sear with ease.
- Wok burner: powerful cooking at up to 4 kW (depending on gas type).
- Low Profile Stainless Steel Cooking Surface is Easily Accessible and Quick to Clean

HEZ211310	Simmer cap
HEZ298105	Simmer plate
HEZ298114	Small pot support
HZ211310	Simmer cap
HZ298105	Simmer plate
HZ298114	Small pot support

Product name/family: .....gas hob w integrated controls  
 Built-in / Free-standing: ..... Built-in  
 Energy input: .....Gas  
 Total number of positions that can be used at the same time: ..... 5  
 Type of control setting devices: .....cylindrical knobs  
 Min. required niche size for installation (HxWxD): .....45 x 850-852 x 490-502 mm  
 Width of the appliance: .....915 mm  
 Dimensions: ..... 58x915x520 mm  
 Dimensions of the packed product (HxWxD): ... 165 x 1110 x 659 mm  
 Net weight: .....21.5 kg  
 Gross weight: ..... 23.7 kg  
 Residual heat indicator: ..... without  
 Location of control panel: ..... Front  
 Basic surface material: ..... Tempered glass  
 Color of surface: .....Black  
 Color of frame: ..... Black  
 Length electrical supply cord: ..... 100.0 cm  
 Knob Material: .....Plastic  
 Sealed Burners: ..... No  
 Power of heating element (kW): ..... 1 kW  
 Power of 3rd heating element (kW): ..... 1.75 kW  
 Power of 5th heating element (kW): ..... 3 kW  
 Connection rating: ..... 1 W  
 Gas connection rating: ..... 11500 W  
 Fuse protection: .....3 A  
 Voltage: ..... 220-240 V  
 Frequency: ..... 50 Hz  
 Energy input: .....Gas  
 Gas type: ..... Liquidgas G30,31 28-30/37 mbar  
 Alternative gas type: ..... Nat gas H/E/(L) 20 (25) mbar  
 Plug type: ..... India plug (6 Ampere)  
 Appliance Dimensions (h x w x d) (in): ..... x x  
 Dimensions of the packed product: ..... 6.49 x 25.94 x 43.70  
 Net weight: .....47.000 lbs  
 Gross weight: ..... 52.000 lbs  
 Total number of positions that can be used at the same time: ..... 5  
 Length electrical supply cord: ..... 100.0 cm  
 Min. required niche size for installation (HxWxD): .....45 x 850-852 x 490-502 mm  
 Dimensions: ..... 58x915x520 mm  
 Dimensions of the packed product (HxWxD): ... 165 x 1110 x 659 mm  
 Net weight: .....21.5 kg  
 Gross weight: ..... 23.7 kg



**Series 6, Gas hob, 90 cm, Tempered  
glass, Black  
PPQ9B6O90I**

---

**Series 6, Gas hob, 90 cm, Tempered glass, Black  
PPQ9B6O90I**

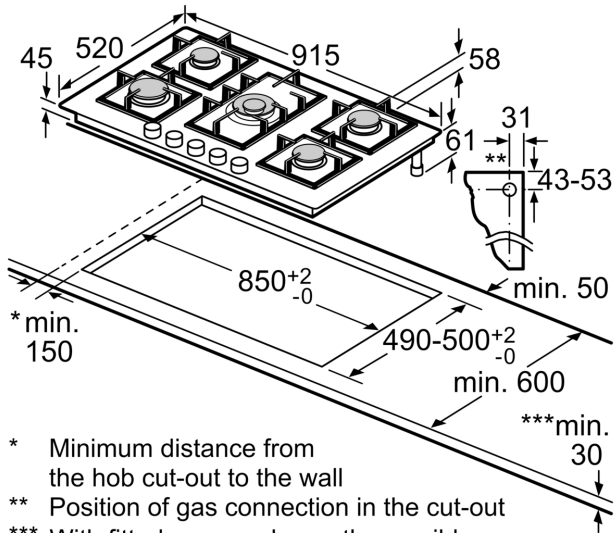

- \* Minimum distance from the hob cut-out to the wall
  - \*\* Position of gas connection in the cut-out
  - \*\*\* With fitted oven underneath, possibly more; see space requirements for the oven
- measurements in mm