

**Series 8, 177.8 x 91.2 cm, Black
KAD92HBFP**



Side-by-Side fridge freezer with innovative noFrost technology and cameras: the cameras in the fridge let you check the content of your fridge from wherever you are, whenever you want.

- **XXL capacity:** extra space for your food when you need it.
- **LED lighting:** keep your groceries in perfect view.
- **Big Box drawer:** for stacking storage containers or for large frozen food items.
- **Easy Access Shelf:** pull-out glass shelf gives you better access to the contents of your fridge.
- **2 Cooling Systems:** separately controllable refrigerator and freezer compartments

FIZ50000 Water filter
KSZ63000 water hose extension

Energy Efficiency Class (Regulation (EU) 2017/1369): F
Average annual energy consumption in kilowatt hour per year (kWh/a) (EU) 2017/1369:419 kWh/annum
Sum of volume of frozen compartments (EU 2017/1369): 209 l
Sum of volume of chill- and unfrozen compartments (EU 2017/1369): 376 l
Airborne acoustical noise emissions (EU 2017/1369):42 dB(A) re 1pW
Airborne acoustical noise emission class (EU 2017/1369): D
Built-in / Free-standing: Freestanding
Number of compressors: 1
Number of independent cooling systems: 2
Width of the appliance: 912 mm
Height: 1778 mm
Depth of the product: 732 mm
Net weight: 159.4 kg
Door panel options: Not possible
Door hinge: left and right
Number of Adjustable Shelves in fridge compartment: 3
Shelves for Bottles: Yes
Frost free system: Fridge
Interior ventilator: No
Reversible Door Hinge: No
Length electrical supply cord: 240.0 cm
Noise level: 42 dB(A) re 1pW
Multi-Flow Air Tower: Yes
Fast cooling switch: Yes
Fast freezing switch: Yes
Temperature Controlled Drawer: No
Humidity Control Drawer: No
Number of Door Bins - Refrigerator: 5
Door bin adjustability - Refrigerator: No
Tilt-out door bins in fridge: Yes
Number of Gallon storage: 2
Number of shelves - Freezer: 2
Shelf Adjustability - Freezer: Yes
Capacity of Water Tank: 1.0 l
Connection rating: 190 W
Fuse protection: 10 A
Voltage: 220-240 V
Frequency: 50-60 Hz
Storage Period in Event of Power Failure (h): 8 h
Door panel options: Not possible
Noise level: 42 dB(A) re 1pW
Energy Star Qualified: No
Required cutout/niche size for installation (in): x
Dimensions of the packed product: 74.25 x 38.58 x 32.87
Net weight: 352.000 lbs
Gross weight: 375.000 lbs



Series 8, 177.8 x 91.2 cm, Black KAD92HBFP

Side-by-Side fridge freezer with innovative noFrost technology and cameras: the cameras in the fridge let you check the content of your fridge from wherever you are, whenever you want.

Consumption

Design and Styling

- Black doors and cast iron body
- alu Vertical handle

Convenience & Safety

- Full frost free - never defrost again
- Separate temperature controls for Fridge and Freezer
- SuperCooling function with automatic deactivation
- Super freeze function
- Door open warning signal: Acoustic door open warning
- Optical and acoustic alarm system Failure memory function

Ice and Water

- Illuminated water and ice dispenser
- In-door ice water dispenser
- Water Filter

Fridge Compartment

- MultiAirflow
- without, 4 safety glass shelves of which 3 are height adjustable
- 2 door shelf, large

Freshness System

Freezer Compartment

- 2 transparent freezer drawers
- 4 door trays in the freezing compartment

Technical Information

- 4 height adjustable feet

Dimensions

- Appliance Height: 1778 mm
- Appliance Width: 912 mm
- Appliance Depth: 732 mm
- Connection value 190 W
- Nominal voltage: 220 - 240 V

Accessories

- 2 x cold accumulator(s)
- connection hose 2 x egg tray(s)

General Information

**Series 8, 177.8 x 91.2 cm, Black
KAD92HBFP**

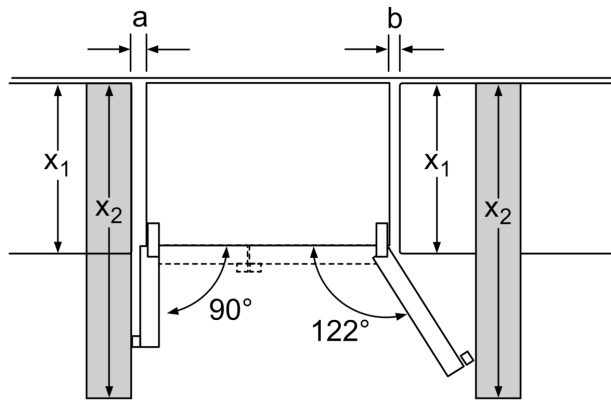
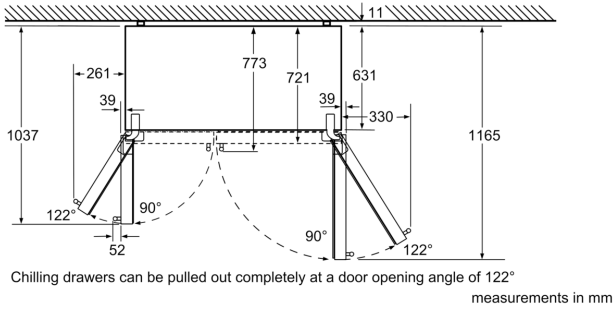

x_1 (unit depth)	a	b
600	39	39
650	39	53
700	39	85
x_2 (wall)	105	330

measurements in mm

measurements in mm

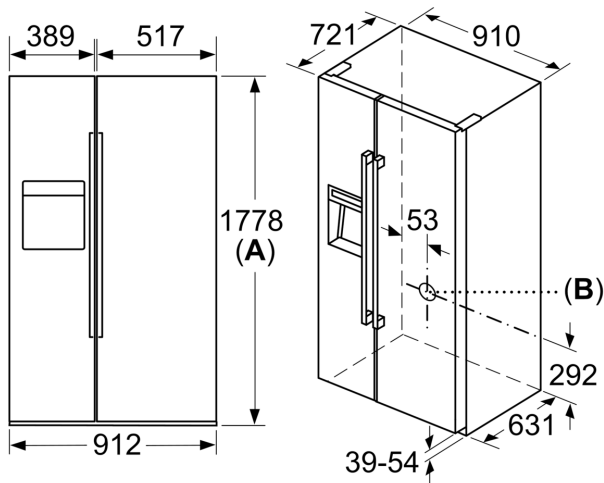

- A:** Front is adjustable from 1769 to 1784
- B:** Water connection to the appliance