

**Serie | 6, Built-in microwave oven,
Stainless steel
HMT84G654K**



Included accessories
1 x grid high

**The built-in microwave for the 38 cm niche:
use it for extra fast thawing, heating and
perfect preparation of foods.**

- **Frameless design:** easy installation, harmonious integration into the kitchen furniture and easy to clean.
- **AutoPilot 8:** every dish is a perfect success thanks to 8 pre-set automatic programmes.
- **Grill function:** perfect grilling results are quickly and easily achieved thanks to a powerful grill.
- **Side-opening door:** convenient opening thanks to left-hinged door.

Technical Data

Type of micro-wave oven :	MW+Grill function
Type of control :	Electronic
Color / Material Front :	Stainless steel
Dimensions of the product (mm) :	382 x 594 x 388
Cavity dimensions (mm) :	208.0 x 328.0 x 369.0
Length electrical supply cord (cm) :	200
Net weight (kg) :	18.651
Gross weight (kg) :	21.0
Maximum micro-wave power (W) :	900
Number of Power Levels :	5
Turntable :	Yes
Heating type :	Microwave
Cavity material :	Stainless steel
Door opening :	Button
Clock :	Yes
Included accessories :	1 x grid high
Main colour of product :	Stainless steel
Height of the product (mm) :	382
Width of the product (mm) :	594
Depth of the product :	388
Maximum micro-wave power (W) :	900
Connection Rating (W) :	1450
Current (A) :	10
Voltage (V) :	220-230
Frequency (Hz) :	50
Color / Material Front :	Stainless steel
Approval certificates :	BIS Standard Mark, CE
Required cutout/niche size for installation (in) :	x x
Appliance Dimensions (h x w x d) (in) :	x x
Dimensions of the packed product (in) :	18.50 x 18.11 x 25.98
Net weight (lbs) :	41
Gross weight (lbs) :	46



Serie | 6, Built-in microwave oven, Stainless steel
HMT84G654K

**The built-in microwave for the 38 cm niche:
use it for extra fast thawing, heating and
perfect preparation of foods.**

Heating Modes

- 5 power levels: 900 W, 600 W, 360 W, 180 W, 90 W
- Cavity volume: 25 l

Design:

- Rotary control knob
- Left-hand
- Stainless steel cavity
- User-friendly electronics with push-buttons and pop-out control.

Key Functions

- 3 weight automatic cooking programmes
- 4 weight automatic defrost programmes
- 8 automatic programming
- Memory-Function (1 setting)
- 31.5 cm glass turntable

Dimensions:

- Dimensions of the product (HxW mm) : 382 x 594
- Length of mains cable: 200 cm
- Electrical connection rating: 1450 W

Serie | 6, Built-in microwave oven, Stainless steel HMT84G654K

Microwave,
corner installation

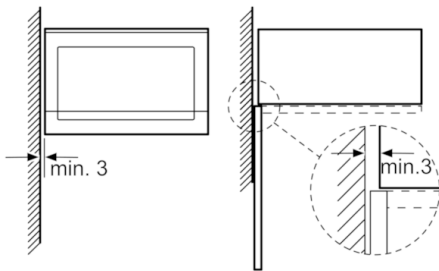

Measurements in mm

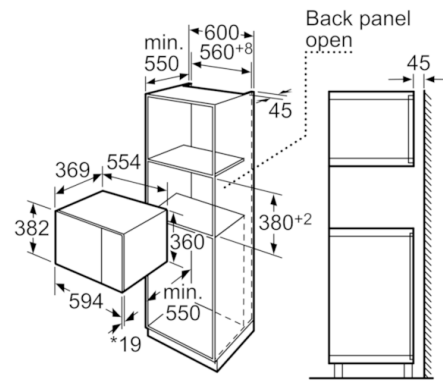

* 20 mm for metal fascias

measurements in mm

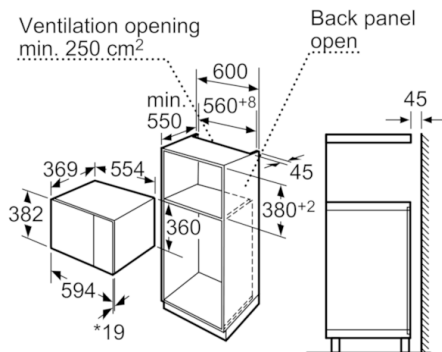

* 20 mm for metal fascias

measurements in mm