

**Series 2, telescopic cooker hood, 60 cm, Black
DHI646CQI**



DHZ2900 Active carbon filter
DWZ1IX1G9 Wall bracket

The telescopic cooker hood: practically disappears into your upper cabinet, giving you a sleek kitchen front.

- **Extraction rate:** Optimal performance to keep your kitchen odour free in no time
- **3-Speed Power Level Options To Suit Your Cooking Style And Recipes**
- **Ducted or Non-ducted Options**

Typology: Pull-out
 Length electrical supply cord: 130.0 cm
 Min. required niche size for installation (HxWxD): 135mm x 598.0mm x 264mm mm
 Net weight:8.0 kg
 Type of control:mechanical
 Number of speed settings:3-stage
 Max. air extraction:300 m³/h
 Max. air recirculation: 100 m³/h
 Number of lights: 2
 Noise level:62 dB(A) re 1 pW
 Diameter of air outlet: 120 / 150 mm
 Grease filter material:Washable aluminium
 Odour filter: No
 Operating Mode:Convertible
 Optional accessories: DHZ2900, DWZ1IX1G9
 Type of lamps used: Halogen
 Total power of the lamps:56 W
 Grease filter type: Multilayer cassette
 Connection rating: 181 W
 Voltage: 220-240 V
 Frequency: 50 Hz
 Plug type: India plug (10 Ampere)
 Installation typology: Built-in into the cabinet
 Material body: Lacquered
 Plug type: India plug (10 Ampere)
 Dimensions of the product, with chimney (if exists) (in):x x
 Dimensions of the packed product: 11.81 x 28.74 x 22.44
 Net weight: 18.000 lbs
 Gross weight: 20.000 lbs
 Motor location: Integrated motor in hood body
 No-return airflow flap: No
 Length electrical supply cord: 130.0 cm
 Dimensions of the product, with chimney (if exists):175 x 600.0 x 280.0 mm
 Dimensions of the packed product (HxWxD): 300 x 730 x 570 mm
 Net weight:8.0 kg
 Gross weight: 9.0 kg



Series 2, telescopic cooker hood, 60 cm, Black DHI646CQI

The telescopic cooker hood: practically disappears into your upper cabinet, giving you a sleek kitchen front.

Design

- Slimline cooker hood
- 60 cm black Standard hood

Performance

- 3 fan speed settings
- Maximum extraction power 310 m³/h (freeblowing)

Comfort

- Total power of motors: 125 W
- Steel filter cover, dishwasher safe
- 2 x 3 W halogen lights
- Light Intensity: 113 lux
- Colour Temperature: 2700 K
- Energy Efficiency Class: E
- Average Energy Consumption: 115.1 kWh/year*
- Blower Efficiency Class: F*
- Lighting Efficiency Class: G*
- Grease Filtering Efficiency Class: C*

Technical Information

- Suitable for ducted or re-circulated extraction
- Dimensions (HxWxD): 175 x 600 x 280 mm
- Cutout Dimensions (HxWxD): 13.5 cm x 59.8 cm x 26.4 cm
- Diameter pipe Ø 150 mm (Ø 120 mm enclosed)
- Total Connected load: 181 W

* In accordance with the EU-Regulation No 65/2014

**Series 2, telescopic cooker hood, 60
cm, Black
DHI646CQI**

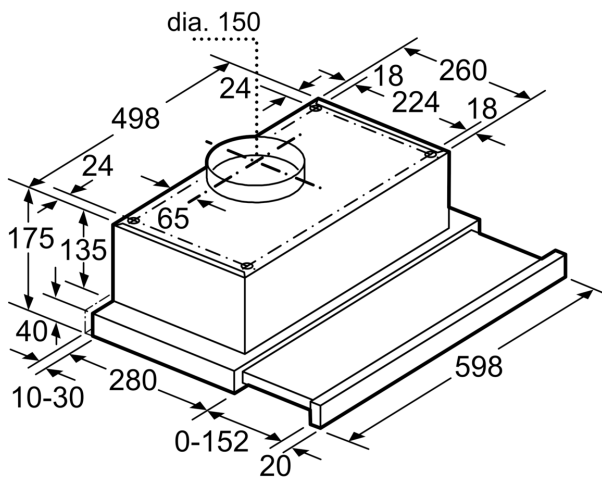

measurements in mm