

**Series 8, Built-In Fully Automatic
Coffee Machine, Stainless steel,
Removable water tank
CTL636ES6**



1 x assembly screws, 1 x scoop, 1 x test strip, 1 x milk container (insulated), 1 x connection hose for milk frother, 1 x milk pipe

- TCZ7003 Accessories small appliances
- TCZ8001A Cleaning tablets
- TCZ8002A Descaling tablets
- TCZ8004A Care set espresso
- TCZ8009N insulated milk container
- Y988081012 :
- Y988081300 :
- Y988081302 :
- Y988081303 :

Built-in / Free-standing: Built-in
 Frothing nozzle: No
 Display: No
 Water protection system: no
 Portion sizes: All cups
 Dimensions: 455x594x375 mm
 Dimensions of the packed product (HxWxD): 540 x 478 x 670 mm
 Min. required niche size for installation (HxWxD): 449 x 558 x 356 mm
 Hot water spout: No
 Standby function: Yes
 Simultaneous preparation of 2 cups: Yes
 Included accessories: 1 x assembly screws, 1 x scoop, 1 x test strip, 1 x milk container (insulated), 1 x connection hose for milk frother, 1 x milk pipe
 Optional accessories: TCZ7003, TCZ8001A, TCZ8002A, TCZ8004A, TCZ8009N, Y988081012, Y988081300, Y988081302, Y988081303
 Fuse protection: 10 A
 Voltage: 220-240 V
 Frequency: 50/60 Hz
 Plug type: GARDY plug w/ earthing
 Product group: Built-in coffee machine
 Product name/family: Built-in coffee machine
 Product name / Commercial code: CTL636ES6
 Typology: fully automatic
 Length electrical supply cord: 170.0 cm
 Maximum height for installation: 449 mm
 Dimensions: 455x594x375 mm
 Dimensions of the packed product (HxWxD): 540 x 478 x 670 mm
 Net weight: 43.000 lbs
 Net weight: 19.7 kg
 Gross weight: 49.000 lbs
 Gross weight: 22.3 kg
 Capacity water container: 2.4 l



Series 8, Built-In Fully Automatic Coffee Machine, Stainless steel, Removable water tank CTL636ES6

- Innovative heating system "sensoFlow system"
- One-touch preparation: Ristretto, Espresso, Espresso macchiato, Coffee, Cappuccino, Latte macchiato, Caffé Latte at the touch of a button
- aromaDouble Shot - Extra strong coffee without compromise in aroma
- Beverage temperature adjustable individually: Coffee: 3 grades, Hot water: 4 grades
- optional Brita intenza water filter: Reduces the lime content of water and filters substances affecting smell and taste

Dimensions:

- TFT display with interactive menu
- Coffee amount setting: 20-250 ml
- Coffee outlet Milk nozzle height adjustable: 15 cm (max): Up to 15 cm (max) high Latte Macchiato glasses fit underneath
- Cappuccino: Prepare two cups simultaneously for all coffee and milk specialities
- Removable 2.4 litre water tank
- Early warning if Water tank shortly empty Bean container shortly empty
- Flexible milk solution: Decide for yourself if you prefer connecting the yes milk container or using any other container, e.g. a milk carton
- Short user manual always at hand inside appliance
- High-value ceramic grinding unit "silent ceram drive"
- Powder amount detection: yes - The grinding unit automatically adjusts to bean variety
- One-touch coffee milk specialities with especially fine-pored milk froth thanks to an innovative milk frother
- Foaming and Hot water functions are available separately
- Reduced heating-up time: fastest first cup
- Water pump with 19 bar pressure
- Separate container for pre-grounded coffee
- 15.000 cup warranty: Consistently high appliance quality from the first cup to the 15,000th (valid for non-commercial use within 24 months)
- Removable brewing unit: Easy and hygienic cleaning under running water
- steam blast: Fully-automatic steam cleaning of the milk system after every beverage
- All milk nozzle parts are easily removable, separable , easy to clean & dishwasher-proof
- single portion cleaning function
- Automatic rinsing program when switch-off, switch-on
- Removable drip dish including container for coffee grounds
- Fully automatic descaling & cleaning program (combined programme "calc'n'clean)
- Reminds in time of water filter change, descaling, cleaningDecalcification
- Containers for water, milk and coffee beans are easily accessible but hidden behind a door, so the kitchen always looks clean
- Bean container with aroma protection lid (500 g volume)
- Adjustable grind settings (multilevel)

- Display language selectable
- Child safety lock: Unintended brewing process not possible
- Total Connected load: 1600 W
- with insulationmilk container with fresh lock-lid (0.5 l volume)
- Appliance Dimensions (H x W x D): 45.5 cm x 59.4 cm x 37.5 cm

**Series 8, Built-In Fully Automatic
Coffee Machine, Stainless steel,
Removable water tank
CTL636ES6**

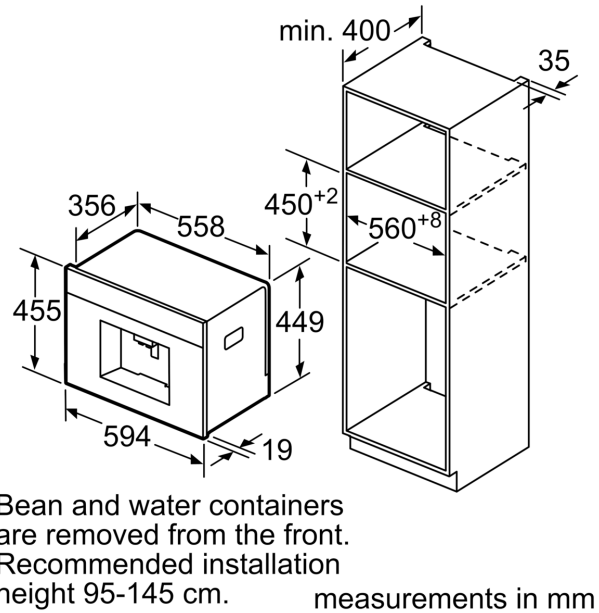
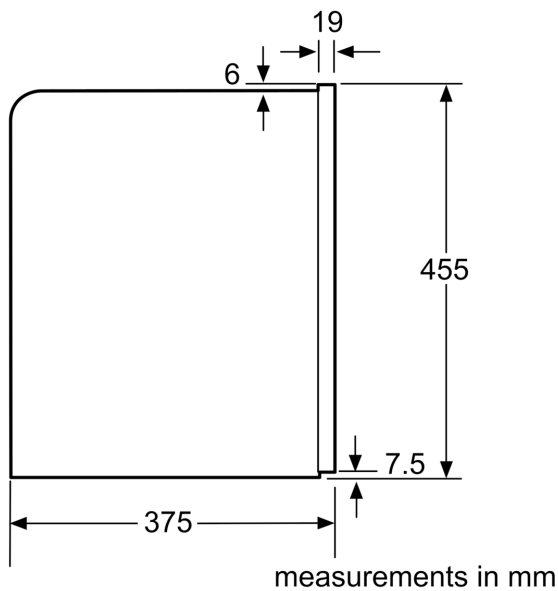

Bean and water containers
are removed from the front.
Recommended installation
height 95-145 cm.

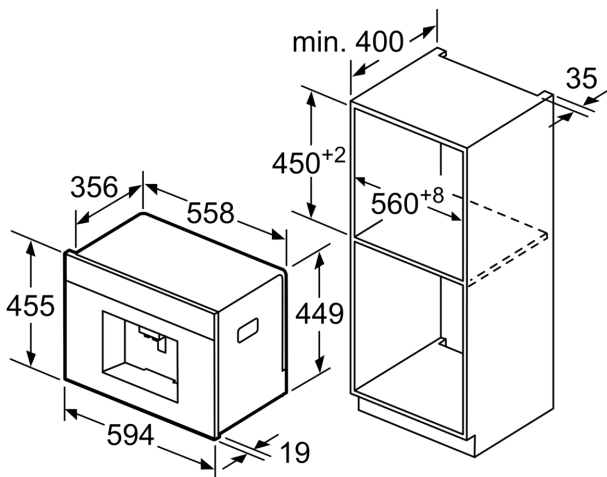

Bean and water containers
are removed from the front.
Recommended installation
height 95-145 cm.

left corner installation

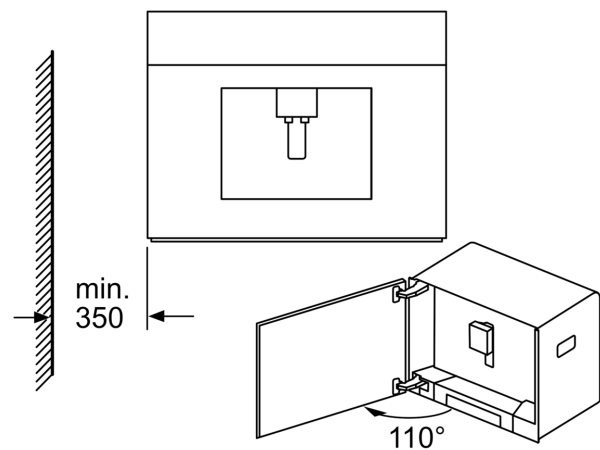

If using the 92° hinge limiter
(spare part no. 00636455),
the minimum distance to the wall
is only 100 mm.

