

**Series 6, heat pump tumble dryer, 9 kg  
WTWH7660GB**



**A++**

**Our Home Connect heatpump dryer with SelfCleaning Condenser. Great performance guaranteed with constantly low energy consumption of A++.**

- **SelfCleaning Condenser:** keep the condenser free of fluff to maintain A++ energy efficiency.
- **AutoDry:** automatically dries to the exact degree of dryness you want.
- **AntiVibration Design:** extremely stable and especially quiet thanks to special vibration protection.
- **Home Connect:** home appliances with smart connectivity for an easier everyday life.
- **Fast drying:** dries a full load considerably fast.

**Technical Data**

Built-in / Free-standing : Free-standing  
 Removable top : No  
 Door hinge : Right  
 Length electrical supply cord : 145.0 cm  
 Height of removable worktop : 0 mm  
 Dimensions of the product : 842 x 598 x 613 mm  
 Net weight : 54.5 kg  
 Fluorinated greenhouse gases : No  
 Type of refrigerant : R290  
 Hermetically sealed equipment : Yes  
 The quantity expressed in CO2 equivalent : 0.000 t  
 EAN code : 4242005081127  
 Connection Rating : 800 W  
 Fuse protection : 10 A  
 Voltage : 220-240 V  
 Frequency : 50 Hz  
 Capacity cotton - NEW (2010/30/EC) : 9.0 kg  
 Energy efficiency rating : A++  
 Energy consumption electric dryer, full load - NEW (2010/30/EC) : 1.97 kWh  
 Standard cotton programme time at full load : 162 min  
 Energy consumption electric dryer, partial load - NEW (2010/30/EC) : 1.16 kWh  
 Standard cotton programme time at partial load : 104 min  
 Weighted annual energy consumption, electric dryer - NEW (2010/30/EC) : 243.0 kWh/annum  
 Weighted programme time : 129 min  
 Average condensation efficiency full load (%) : 91 %  
 Average condensation efficiency partial load (%) : 91 %  
 Weighted condensation efficiency (%) : 91 %



**Optional accessories**

WTZ27400 : Stacking kit with pull-out shelf  
 WTZ27410 : Stacking kit



## Series 6, heat pump tumble dryer, 9 kg WTWH7660GB

### Our Home Connect heatpump dryer with SelfCleaning Condenser. Great performance guaranteed with constantly low energy consumption of A++.

#### Performance

- Energy Efficiency Class<sup>1</sup>: A++
- Energy<sup>2</sup>: 243 kWh
- Capacity: 1 - 9 kg
- Programme time<sup>3</sup>: 162 min
- Noise level: 64 dB (A) re 1 pW
- Condensation efficiency class<sup>4</sup>: A
- Condensation efficiency<sup>5</sup>: 91 %

#### Programmes/functions

- Touch control buttons: Buzzer, Reduced ironing, start/pause, Drying aim, Child lock 3 sec., Reduced ironing 60 mins, Reduced ironing 120 mins, My favorite, Remote Start, 24 h end Time Delay, Reduced ironing, Reduced ironing 120 mins, Reduced ironing 60 mins, Child lock 3 sec., Drying aim, My favorite, end Time Delay, Remote Start, Buzzer, start/pause
- Fully electronic control dial for sensor drying programmes and timed programmes
- Special programmes: Woollens, Mixed Load, Towels, Duvet, Timed programme warm, Timed programme cold, Cottons, Easy-Care, Allergy +, Sportswear, Down, Super Quick 40, shirts/blouses, Delicates

#### Key features

- Home Connect: Remote Monitoring and Control, Energy Management Photovoltaic
- ActiveAir Technology
- Heat Pump with self cleaning condenser
- Heat pump technology with climate friendly cooling agent
- Sensitive drying: large stainless steel drum with textile care and revolution drying system
- AntiVibration design: for greater stability and quietness

#### Additional features

- Large touch-LED-display for Buzzer, Reduced ironing, end Time Delay, start/pause, Drying aim, Child lock 3 sec.,

Reduced ironing 60 mins, Reduced ironing 120 mins, My favorite

- Inclined ergonomic control panel, slide-under at height of 85 cm
- Jog dial
- Anti crease cycle 120 min at the end of the programme
- Drum interior light
- Full container tank indicator
- Door hinge: right-hand
- Container for condensed water
- Child Lock
- Buzzer to indicate the end of cycle

#### Technical Information

- Dimensions (H x W x D): 84.2 x 59.8 x Appliance depth: 66.5 cm
- slide-under installation
- Glass door,, silver-white

<sup>1</sup> At a range of energy efficiency classes from A+++ to D

<sup>2</sup> Energy consumption kWh per year, based on 160 drying cycles of the standard cotton programme at full and partial load, and the consumption of the low power modes

<sup>3</sup> Programme time of the standard cotton programme at full load

<sup>4</sup> On a condensation efficiency class scale from A to G

<sup>5</sup> Weighted condensation efficiency for the standard cotton programme at full and partial load

**Series 6, heat pump tumble dryer, 9 kg  
WTWH7660GB**

Measurements in mm

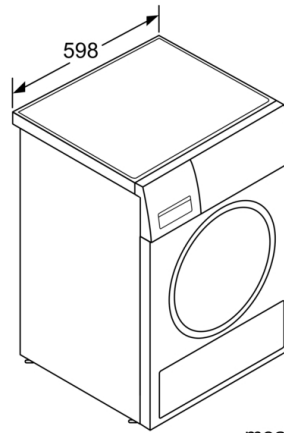
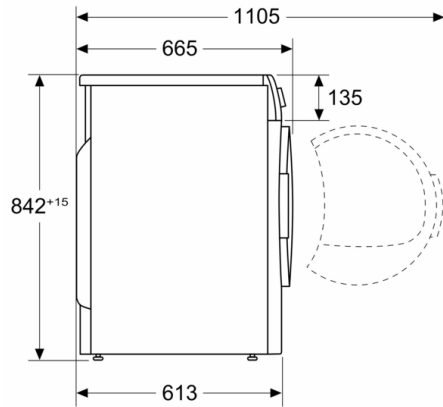

measurements in mm