

**Series 6, Washing machine, front loader, 9 kg, 1400 rpm
WGG244FRGB**



Perfect results with minimum energy, water and detergent consumption thanks to energy Class A, i-DOS automatic dosing and ActiveWater Plus.

- **i-DOS:** Save water and detergent.
- **Iron Assist:** Reduces wrinkles and your ironing pile
- **A rated:** save energy with our most efficient A rated appliances
- **Active Water Plus:** uses only the precise amount of water needed for every wash.
- **Speed Perfect:** Cuts the cycle time by up to 65%* without compromising on results.

Energy Efficiency Class: A
 Weighted energy consumption in kWh per 100 washing cycles of eco 40-60 programme: 46 kWh
 Maximum capacity in kg: 9.0 kg
 The water consumption of the eco programme in liters per cycle: 48 l
 Duration of eco 40-60 programme in hours and mins at rated capacity: 3:48 h
 Spin-drying efficiency class of eco 40-60 programme: B
 Airborne acoustical noise emission class: A
 Airborne acoustical noise emissions : 71 dB(A) re 1pW
 Built-in / Free-standing: Free-standing
 Dimensions of the product: 848x598x590 mm
 Net weight: 73.5 kg
 Connection rating: 2300 W
 Fuse protection: 10 A
 Voltage: 220-240 V
 Frequency: 50-60 Hz
 Length electrical supply cord: 210.0 cm
 Door hinge: Left
 Wheels: No
 EAN code: 4242005395446
 Installation typology: Free-standing

WMZ2200 Floor securing component
 WMZ2381 Extension for cold water inlet /Aquastop



Series 6, Washing machine, front loader, 9 kg, 1400 rpm WGG244FRGB

Perfect results with minimum energy, water and detergent consumption thanks to energy Class A, i-DOS automatic dosing and ActiveWater Plus.

Performance

- Energy Efficiency Class¹: A
- Energy² / Water³: 46 kWh / 48 litres
- Load capacity: 1 - 9 kg
- Programme duration⁴: 3:48 h:min
- Spin drying efficiency class: B
- Spin speed^{**}: 400 - 1400 rpm
- Noise level: 71 dB (A) re 1 pW
- Noise efficiency class: A

Programmes/functions

- Standard programmes: cottons, easy care, delicates, wool hand wash
- W_F44-CA10-Ahi-i
- Iron Assist: Steam programme that reduces wrinkles on dry clothes
- Special programmes: Automatic Gentle, Drum clean with reminder, Drain / Spin, Mixed Load, SportsWear, Single Rinse, Super Quick 15/30, Hygiene

Key features

- SpeedPerfect: perfectly clean in up to 65% less time. ***
- i-DOS: automatic dosing of liquid detergent and softener
- AntiStain - 4 stain removal options at the touch of a button
- Touch control buttons: Reduced Ironing option, Ready in, stain selection, i-DOS 2.0, start/pause with reload function, Temperature selection, SpeedPerfect, Prewash, Spin speed reduction/Rinse Hold

Additional features

- Reload function: Be flexible in adding laundry items even after start of the wash cycle.
- Large LED-Display for programme status indication, max. spin speed, remaining time and 24 h end time delay and load recommendation
- Hygiene Plus: clean laundry and killing germs effectively
- Drum volume: 65 litres
- Usage meter: counts completed programmes
- Drum interior light
- VarioDrum: gentle and efficient washing
- Drum clean with reminder function
- Large silver-black grey door with 165° opening and 32cm porthole opening
- Reload function / pause function
- EcoSilence drive with 10 year warranty
- EcoSilence drive with 10 year warranty
- ActiveWater Plus: for highly efficient use of water even with small loads thanks to automatic load detection.
- AntiStain
- AntiVibration Design - for more stability and quietness

- Turbidity sensor
- Aqua Protection
- soft dial
- Foam detection system
- Sensor electronics with safeguard monitoring system that adjusts load and distribution and programme settings to protect clothes
- Child lock
- Acoustic signals: Buzzer

Technical Information

- Slide-under installation
- Dimensions (H x W): 84.8 cm x 59.8 cm
- Appliance depth: 59.0 cm
- Appliance depth incl. door: 63.6 cm
- Appliance depth with open door: 107.3 cm

¹ Scale of Energy Efficiency Classes from A to G

² Energy consumption in kWh per 100 cycles (in programme Eco 40-60)

³ Weighted water consumption in litres per cycle (in programme Eco 40-60)

⁴ Duration of Eco 40-60 programme

** Values are rounded.

*** Comparison between the program duration of Easy-care 40°C and the program duration of Easy-care 40°C + activated Speed option

**Series 6, Washing machine, front loader, 9 kg, 1400 rpm
WGG244FRGB**

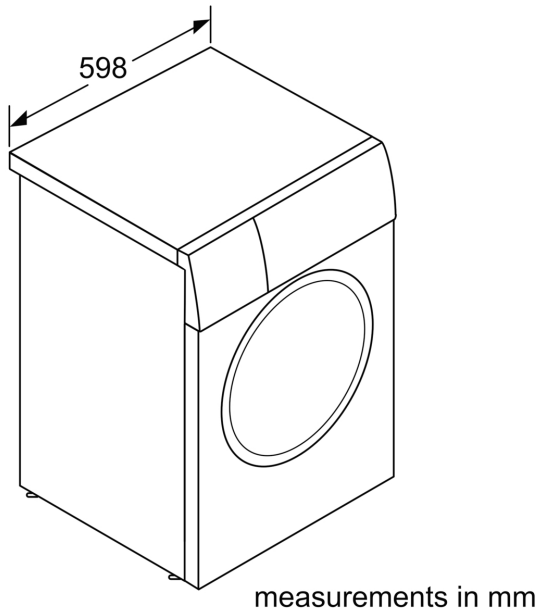

Measurements in mm

