

**Series 2, fully-integrated dishwasher,
60 cm
SMV2ITX22G**



- SMZ5003 Retractable hinge f. high corpus dimens.
- SMZ2056 Attachment door, stainless steel
- SGZ1010 inlet and outlet hose extension
- SGZ8BI00 Connection rail for divided furniture
- SMZ1051EU Mains cable with EU-Plug 5m
- SMZ5300 GlassSecure Tray

Connected dishwasher with noise reduction at any time via the Home Connect App.

- **Home Connect:** home appliances with smart connectivity for an easier everyday life.
- **ExtraDry:** extra drying option for difficult-to-dry loads.
- **Silence on demand:** up to 30 min noise reduction at any time via the Home Connect App.
- **Height Adjustable Top Basket:** offers extra space, especially for tall dishes.
- **InfoLight:** a red infolight on the floor indicates whether the dishwasher is switched on or off.

Energy Efficiency Class: E
 Energy Consumption for 100 cycles Eco Programme: 92 kWh
 Maximum number of place settings: 12
 The water consumption of the eco programme in liters per cycle: 10.5 l
 Programme duration: 4:30 h
 Airborne acoustical noise emissions : 48 dB(A) re 1 pW
 Airborne acoustical noise emission class: C
 Built-in / Free-standing: Built-in
 Height of removable worktop: 0 mm
 Dimensions of the product (HxWxD): 815 x 598 x 550 mm
 Min. required niche size for installation (HxWxD): 815-875 x 600 x 550 mm
 Depth with open door 90 degree: 1150 mm
 Adjustable feet: Yes - all from front
 Maximum adjustability feet: 60 mm
 Adjustable plinth: Both horizontal and vertical
 Net weight: 31.2 kg
 Gross weight: 33.3 kg
 Connection rating: 2400 W
 Fuse protection: 10 A
 Voltage: 220-240 V
 Frequency: 50; 60 Hz
 Length electrical supply cord: 175.0 cm
 Plug type: GB plug
 Length inlet hose: 165 cm
 Length outlet hose: 190 cm
 EAN code: 4242005275175
 Installation typology: Integrated



Series 2, fully-integrated dishwasher, 60 cm SMV2ITX22G

Connected dishwasher with noise reduction at any time via the Home Connect App.

³ Water consumption in litres per cycle (in programme Eco 50 °C)

⁴ Duration of programme Eco 50 °C

* Please find warranty terms under <https://www.siemens-home.bsh-group.com/uk/customer-service/warranty/additional-warranties>

New for 2021

Performance

- Energy Efficiency Class¹: E
- Energy² / Water³: 92 kWh / 10.5 litres
- Capacity: 12 place settings
- Programme duration⁴: 4:30 (h:min)
- Noise level: 48 dB(A) re 1 pW
- Noise Efficiency Class: C

Programmes / functions

- 5 programmes: Eco 50 °C, Auto 45-65°, Intensive 70 °C, Express 65°, Favourite
- Default favourite programme: Pre-Rinse
- 4 special options: Remote Start, Extra Dry, Half Load, SpeedPerfect
- Machine Care
- Silence on Demand (via app)

Flexible design elements

- Vario baskets
- Height adjustable top basket
- Low friction wheels on lower basket
- Rack Stopper to prevent derailing of bottom basket
- 2 foldable plate racks in bottom basket
- Cutlery basket in lower rack

Innovations and technology

- Home Connect ready on WLAN
- DosageAssist detergent dispenser
- EcoSilence BLDC drive
- Automatic detergent detection
- AquaSensor III
- AquaMix - Glass protection system

Design features

- Push button top edge controls
- InfoLight (Red) - Light projection on the floor
- Time delay (3, 6 or 9 hours)
- AquaStop: Bosch's warranty in case of water damage - for the lifetime of the appliance. Please find warranty terms under <https://www.bosch-home.co.uk/customer-service/care-protection-and-parts/additional-warranties>
- Self cleaning filter system with 3 piece corrugated filter
- Large item spray head, steam protection plate
- Stainless steel/Polinox interior
- Dimensions (HxWxD): 81.5 x 59.8 x 55cm

¹ Scale of Energy Efficiency Classes from A to G

² Energy consumption in kWh per 100 cycles (in programme Eco 50 °C)

**Series 2, fully-integrated dishwasher,
60 cm
SMV2ITX22G**

measurements in mm

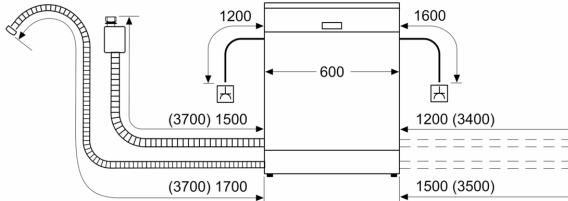

⏏ socket
() values with extension kit

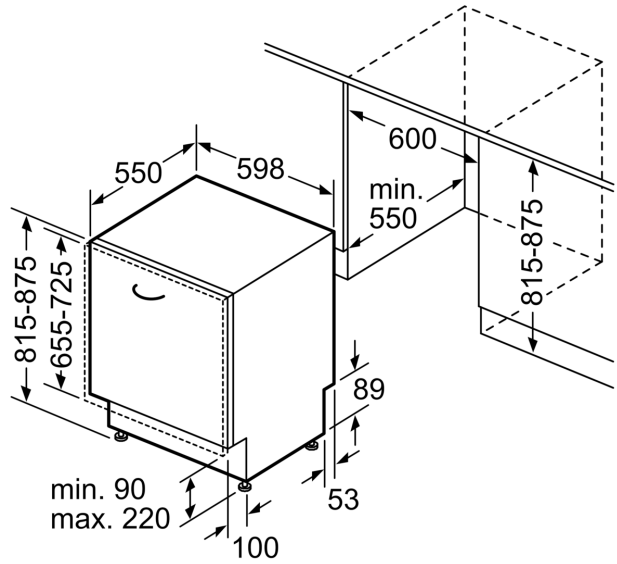

measurements in mm