

**Series 4, built-in fridge-freezer with freezer at bottom, 177.2 x 54.1 cm, sliding hinge
KIV85VSF0G**



The bottom freezer with MultiBox: lots of space for your fruits and vegetables.

- LED lighting - with soft start, lasts for the lifetime of the appliance.
- **VarioZone:** more flexibility due to variable-use glass shelves and drawers in the freezer compartment.
- **Big Box drawer:** for stacking storage containers or for large frozen food items.
- **LowFrost:** defrost less often thanks to lower ice formation - saves work and is energy-efficient.
- FreshSense sensors constantly monitor and control the ambient, fridge and freezer temperature

Technical Data

Energy Efficiency Class: F
 Average annual energy consumption in kilowatt hour per year (kWh/a): 285 kWh/annum
 Sum of volume of frozen compartments: 102 l
 Sum of volume of chill compartments: 159 l
 Airborne acoustical noise emissions : 38 dB(A) re 1 pW
 Airborne acoustical noise emission class: C
 Built-in / Free-standing: Built-in
 Door panel options: Not possible
 Width of the appliance: 541 mm
 Depth: 545 mm
 Required niche size for installation (HxWxD): 1775.0 x 560 x 550 mm
 Net weight: 63.5 kg
 Connection Rating: 90 W
 Fuse protection: 13 A
 Door hinge: Right reversible
 Voltage: 220-240 V
 Frequency: 50 Hz
 Approval certificates: CE, VDE
 Length electrical supply cord: 230 cm
 Storage Period in Event of Power Failure (h): 10 h
 Number of compressors: 1
 Number of independent cooling systems: 1
 Interior ventilator: No
 Reversible Door Hinge: Yes
 Number of Adjustable Shelves in fridge compartment: 3
 Shelves for Bottles: No
 Frost free system: No
 Installation typology: Full-integrated
 Type of hinge: Follow-door

Included accessories

3 x egg tray
 1 x ice cube tray



Series 4, built-in fridge-freezer with freezer at bottom, 177.2 x 54.1 cm, sliding hinge KIV85VSF0G

The bottom freezer with MultiBox: lots of space for your fruits and vegetables.

Additional features

- EU19_EEK_D: F
- Total Volume : 261 l
- Net Fridge Volume : 159 l
- Net Freezer Volume : 102 l
- Freezing capacity 24h : 4.6 kg
- Annual Energy Consumption: 285 kWh/a
- Climate Class: SN-ST
- EU19_Fast freezer facility_D: yes
- Noise Level : 38 dB
- Temperature rise time : EU19_Temperature rise time_D: 10 H

Performance and Consumption

Functions

Design features

- LED electronic control
- Automatic defrost fridge

Design features

- 4 safety glass shelves in fridge compartment of which 3 are height adjustable
- 1 removable door storage compartments.

Freshness System

- 1 MultiBox - Transparent drawer with a rippled bottom, ideal for storing fruits and vegetables.

Food freshness system

- 4 freezer drawers

Dimension and installation

- Dimensions: 177.2 cm H x 54.1 cm W x 54.5 cm D
- Niche Dimensions: 177.5 cm H x 56 cm W x 55 cm D

Key features - Fridge section

- Right hinged door, reversible door
- Connection value 90 W
- 220 - 240 V

Key features - Freezer section

- 3 x egg tray, 1 x ice cube tray

Country Specific Options

- Based on the results of the standard 24-hour test. Actual consumption depends on usage/position of the appliance.

Design features

Dimension and installation

Series 4, built-in fridge-freezer with freezer at bottom, 177.2 x 54.1 cm, sliding hinge KIV85VSF0G

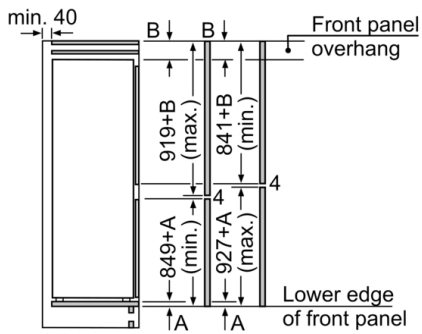

The specified unit door dimensions are valid for a door gap of 4 mm.
measurements in mm

