

**Series 2, built-in fridge-freezer with freezer at bottom, 193.5 x 54.1 cm, sliding hinge  
KIN96NSE0**



KSZB6R00 Bottle Rack  
KSZGGM00 Butter box

**The extra large built-in fridge freezer with 12% more cooling volume including Multi Box XXL drawer for fruit and vegetables, No Frost and error warning signal for optimal storage.**

- **Built-in XL:** get 11% extra volume of storage thanks to a taller design.
- **No Frost:** never defrost again, thanks to perfect protection from ice formation - that saves time and effort.
- **An audible alarm system signals the door is open**
- **LED lighting:** all your items in perfect view.
- **Two cooling systems:** separately controllable fridge and freezer compartments

Energy Efficiency Class: .....	E
Average annual energy consumption in kilowatt hour per year (kWh/a): .....	231 kWh/annum
Sum of volume of frozen compartments: .....	75 l
Sum of volume of chill compartments: .....	215 l
Airborne acoustical noise emissions : .....	34 dB(A) re 1pW
Airborne acoustical noise emission class: .....	B
Built-in / Free-standing: .....	Built-in
Door panel options: .....	Not possible
Height: .....	1935 mm
Width of the appliance: .....	541 mm
Depth: .....	548 mm
Required niche size for installation (HxWxD): ...	1940 x 560 x 550 mm
Net weight: .....	54.8 kg
Fuse protection: .....	10 A
Door hinge: .....	Right reversible
Voltage: .....	220-240 V
Frequency: .....	50 Hz
Length electrical supply cord: .....	230.0 cm
Number of compressors: .....	1
Number of independent cooling systems: .....	2
Interior ventilator: .....	No
Reversible Door Hinge: .....	Yes
Number of Adjustable Shelves in fridge compartment: .....	4
Shelves for Bottles: .....	No
No Frost free system: .....	Fridge and freezer
Installation typology: .....	Integrated



## **Series 2, built-in fridge-freezer with freezer at bottom, 193.5 x 54.1 cm, sliding hinge KIN96NSE0**

**The extra large built-in fridge freezer with 12% more cooling volume including Multi Box XXL drawer for fruit and vegetables, No Frost and error warning signal for optimal storage.**

### **Country Specific Options**

- Based on the results of the standard 24-hour test. Actual consumption depends on usage/position of the appliance.

### **Design features**

- Built-in fridge-freezer
- Right hinged door, reversible door
- Height adjustable front feet
- Bright interior LED fridge light
- Separate, electronic temperature control with LED display

### **Functions**

- Automatic defrost fridge
- NoFrost freezer, never have to defrost ever again
- Two separate cooling circuits allow independent temperature control and prevents the transference of humidity between the fridge and freezer cavity
- SuperCool function
- Optical and acoustic door open alarm

### **Food freshness system**

- 1 MultiBox - Transparent drawer with a rippled bottom, ideal for storing fruits and vegetables.

### **Key features - Fridge section**

- 5 safety glass shelves in fridge compartment of which 4 are height adjustable
- Door shelves in fridge door: 1 large and 3 small

### **Key features - Freezer section**

- 3 freezer drawers

### **Additional features**

- 1 x ice cube tray

### **Performance and Consumption**

- Climate Class: SN-ST
- Total Volume : 290 l
- Net Fridge Volume : 215 l
- Net Freezer Volume : 75 l
- Annual Energy Consumption: 231 kWh/a
- Noise Level : 34 dB
- Temperature rise time : EU19\_Temperature rise time\_D: 10 H
- Freezing capacity 24h : 7.5 kg
- 220 - 240 V
- EU19\_EEK\_D: E
- EU19\_Fast freezer facility\_D: yes

### **Dimension and installation**

- Dimensions: 193.5 cm H x 54.1 cm W x 54.8 cm D
- Niche Dimensions: 194 cm H x 56 cm W x 55 cm D
- Length of power cord: 230 cm

**Series 2, built-in fridge-freezer with  
freezer at bottom, 193.5 x 54.1 cm,  
sliding hinge  
KIN96NSE0**

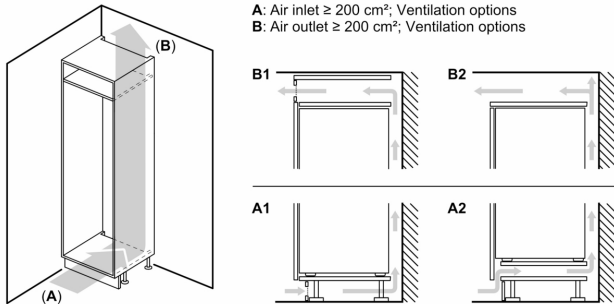

**Measurements in mm**

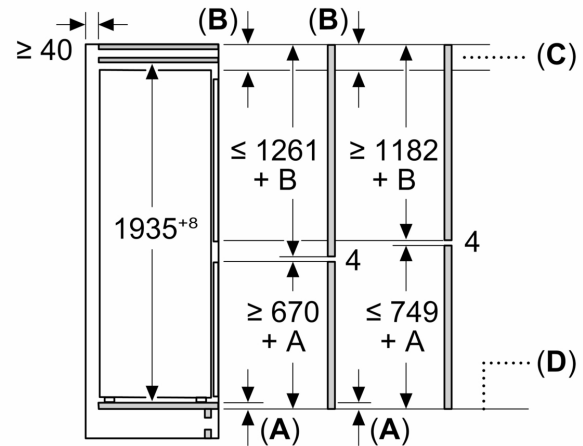

**C:** Front panel overhang

**D:** Lower edge of front panel

**Measurements in mm**

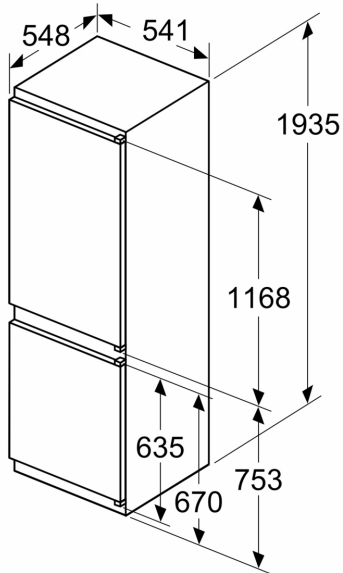

**Measurements in mm**

