

**Series 4, built-in fridge-freezer with freezer at bottom, 177.2 x 54.1 cm, flat hinge
KIN86VFF0G**



Included accessories

3 x egg tray
1 x ice cube tray



The bottom freezer with MultiBox and electronic temperature control: set the temperature easily and precisely.

- LED lighting - with soft start, lasts for the lifetime of the appliance.
- **VarioZone:** more flexibility due to variable-use glass shelves and drawers in the freezer compartment.
- **Automatic super freezing:** optimal for freezing smaller food loads faster whilst protecting your frozen items from defrosting
- **Big Box drawer:** for stacking storage containers or for large frozen food items.
- **NoFrost:** never defrost again, thanks to perfect protection from ice formation - that saves time and effort.

Technical Data

Energy Efficiency Class: F

Average annual energy consumption in kilowatt hour per year (kWh/a): 277 kWh/annum

Sum of volume of frozen compartments: 67 l

Sum of volume of chill compartments: 187 l

Airborne acoustical noise emissions : 39 dB(A) re 1 pW

Airborne acoustical noise emission class: C

Built-in / Free-standing: Built-in

Door panel options: Not possible

Width of the appliance: 541 mm

Depth: 545 mm

Required niche size for installation (HxWxD): 1775.0 x 560 x 550 mm

Net weight: 65.0 kg

Connection Rating: 90 W

Fuse protection: 13 A

Door hinge: Right reversible

Voltage: 220-240 V

Frequency: 50 Hz

Approval certificates: CE, VDE

Length electrical supply cord: 230 cm

Storage Period in Event of Power Failure (h): 8 h

Number of compressors: 1

Number of independent cooling systems: 1

Interior ventilator: Yes

Reversible Door Hinge: Yes

Number of Adjustable Shelves in fridge compartment: 3

Shelves for Bottles: No

Frost free system: Freezer

Installation typology: Full-integrated

Type of hinge: Flush-folding



4 242005 149971

Series 4, built-in fridge-freezer with freezer at bottom, 177.2 x 54.1 cm, flat hinge KIN86VFF0G

The bottom freezer with MultiBox and electronic temperature control: set the temperature easily and precisely.

Key features - Freezer section

- 3 x egg tray, 1 x ice cube tray
- Based on the results of the standard 24-hour test. Actual consumption depends on usage/position of the appliance.

Additional features

Performance and Consumption

- EU19_EEK_D: F
- Total Volume : 254 l
- Net Fridge Volume : 187 l
- Net Freezer Volume : 67 l
- Freezing capacity 24h : 6 kg
- Annual Energy Consumption: 277 kWh/a
- Climate Class: SN-ST
- Noise Level : 39 dB
- Temperature rise time : EU19_Temperature rise time_D: 8.5 H

Functions

- Bright interior LED fridge light

Design features

- Electronic LED display
- FreshSense - Constant temperature control by intelligent sensor technology
- SuperFreeze functions with automatic deactivation

Design features

- 4 safety glass shelves of which 3 are height adjustable
- 4 door bins

Freshness System

- 1 MultiBox - Transparent drawer with a rippled bottom, ideal for storing fruits and vegetables.

Food freshness system

- NoFrost freezer, never have to defrost ever again
- Vario Zone - removable safety glass shelves for extra space!
- 3 transparent freezer drawers, including 1 BigBox

Dimension and installation

- Dimensions: 177.2 cm H x 54.1 cm W x 54.5 cm D
- Niche Dimensions: 177.5 cm H x 56 cm W x 55 cm D

Key features - Fridge section

- Right hinged door, reversible door
- Connection value 90 W
- 220 - 240 V

Series 4, built-in fridge-freezer with freezer at bottom, 177.2 x 54.1 cm, flat hinge KIN86VFF0G

measurements in mm
Recommended gap dimensions for flat hinges

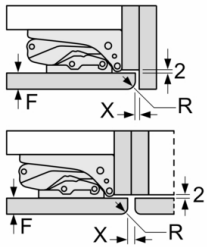

F	R	X
16-19	0-3	2.5
20	0-1	3
	2-3	2.5
21	0-1	3
	2-3	2.5
22	0	4
	1	3.5
	2-3	3

The gap dimensions recommended in the table must be adhered to in order to ensure that appliance doors do not collide with anything when they are opened, and to avoid causing damage to kitchen units.

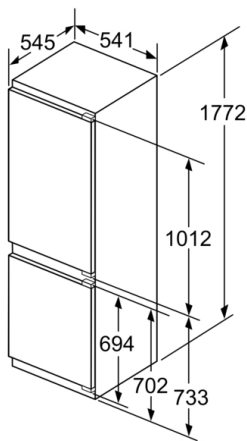
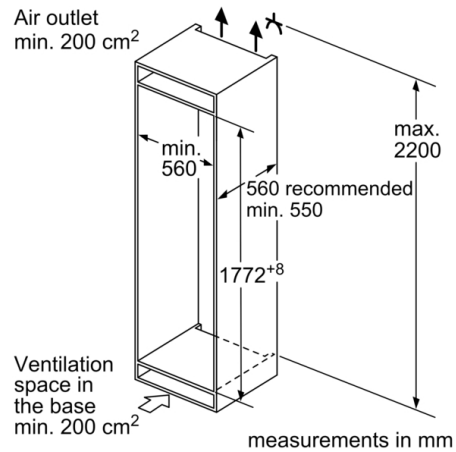

measurements in mm

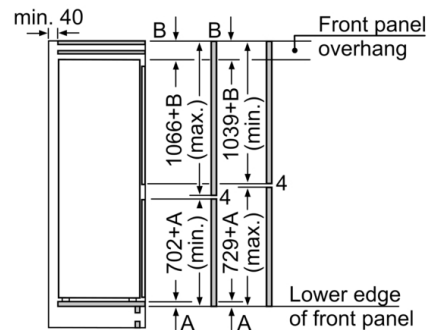

The specified unit door dimensions are valid for a door gap of 4 mm.
measurements in mm

