

**Series 4, built-in fridge-freezer with freezer at bottom, 193.5 x 70.8 cm, flat hinge
KBN96VFE0G**



KSZGGM00 Butter box

Built-in fridge freezer with XXL capacity and VitaFresh near <0°C>: big boost in fridge capacity and ideal storage conditions for all your food.

- **Built-in XL:** get 11% extra volume of storage thanks to a taller design.
- **VitaFresh XXL <0°C>:** keeps food fresh for longer in extra-large climate-controlled fridge drawers.
- **No Frost:** never defrost again, thanks to perfect protection from ice formation - that saves time and effort.
- **LED Lighting:** all your items in perfect view.
- **Super Cool function:** cools new food faster, to protect what is already inside.

Energy Efficiency Class:	E
Average annual energy consumption in kilowatt hour per year (kWh/a):	256 kWh/annum
Sum of volume of frozen compartments:	98 l
Sum of volume of chill compartments:	285 l
Airborne acoustical noise emissions :	34 dB(A) re 1pW
Airborne acoustical noise emission class:	B
Built-in / Free-standing:	Built-in
Door panel options:	Not possible
Height:	1935 mm
Width of the appliance:	708 mm
Depth:	548 mm
Required niche size for installation (HxWxD): ...	1940 x 710 x 560 mm
Net weight:	70.2 kg
Fuse protection:	10 A
Door hinge:	Right reversible
Voltage:	220-240 V
Frequency:	50 Hz
Length electrical supply cord:	230.0 cm
Number of compressors:	1
Number of independent cooling systems:	2
Interior ventilator:	No
Reversible Door Hinge:	Yes
Number of Adjustable Shelves in fridge compartment:	4
Shelves for Bottles:	Yes
Frost free system:	Fridge and freezer
Installation typology:	Integrated



Series 4, built-in fridge-freezer with freezer at bottom, 193.5 x 70.8 cm, flat hinge KBN96VFE0G

Built-in fridge freezer with XXL capacity and VitaFresh near <0°C>: big boost in fridge capacity and ideal storage conditions for all your food.

- Dimensions: 193.5 cm H x 70.8 cm W x 54.8 cm D
- Fixed hinge, softClosing door: No

Design features

- Built-in fridge-freezer
- NoFrost freezer, never have to defrost ever again
- Right hinged door, reversible door
- Heavy load hinge set
- Height adjustable front feet
- Bright interior LED fridge light
- Separate, electronic temperature control with LED display
- Home Connect: iService Remote, Remote Monitoring and Control with Wi-Fi connectivity

Functions

- Automatic defrost fridge
- Two separate cooling circuits allow independent temperature control and prevents the transference of humidity between the fridge and freezer cavity
- SuperCool function
- acoustic for Fridge and Freeze, Acoustic alarm, Optical and acoustic door open alarm

Food freshness system

- 1 VitaFresh drawer with humidity control - Fruits and vegetables retain vitamins and stay fresh for longer

Key features - Fridge section

- 5 safety glass shelves in fridge compartment of which 4 are height adjustable
- Door shelves in fridge door: 1 large and 3 small
- Bottle rack

Key features - Freezer section

- 3 freezer drawers

Additional features

- 3 x egg tray, 1 x ice cube tray

Performance and Consumption

- Climate Class: SN-ST
- Total Volume : 383 l
- Net Fridge Volume : 285 l
- Net Freezer Volume : 98 l
- Annual Energy Consumption: 256 kWh/a
- Noise Level : 34 dB
- Temperature rise time : EU19_Temperature rise time_D: 13 H
- Freezing capacity 24h : 9.5 kg
- 220 - 240 V
- EU19_EEK_D: E

- EU19_Fast freezer facility_D: yes
- Based on the results of the standard 24-hour test. Actual consumption depends on usage/position of the appliance.

Dimension and installation

- Niche Dimensions: 194 cm H x 71 cm W x 56 cm D
- Length of power cord: 230 cm

Country Specific Options

**Series 4, built-in fridge-freezer with
freezer at bottom, 193.5 x 70.8 cm,
flat hinge
KBN96VFE0G**

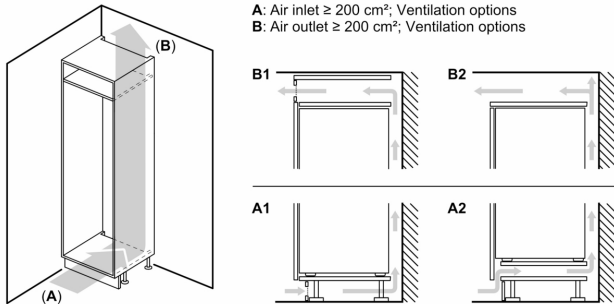

Measurements in mm

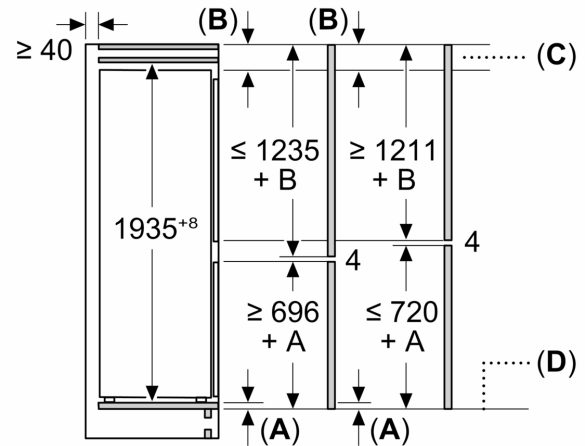

C: Front panel overhang

D: Lower edge of front panel

Measurements in mm

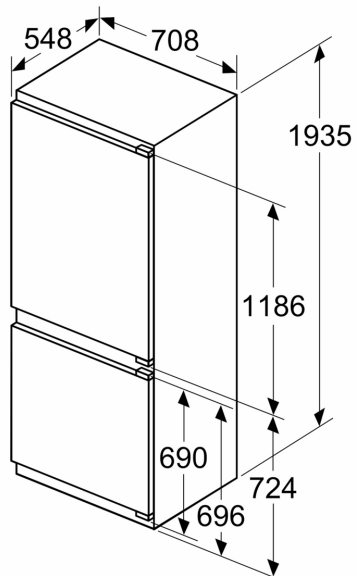

Measurements in mm

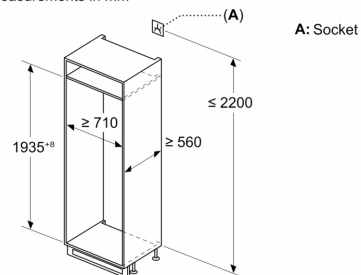

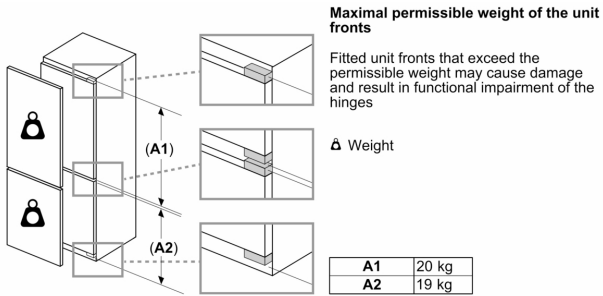

measurements in mm
Recommended gap dimensions for flat hinges

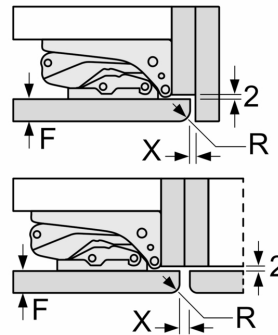

F	R	X
16-19	0-3	2.5
20	0-1	3
	2-3	2.5
21	0-1	3
	2-3	2.5
22	0	4
	1	3.5
	2-3	3

The gap dimensions recommended in the table must be adhered to in order to ensure that appliance doors do not collide with anything when they are opened, and to avoid causing damage to kitchen units.