

**Series 4, American side by side,
178.7 x 90.8 cm, Brushed steel
anti-fingerprint
KAN93VIFPG**



**The NoFrost side-by-side fridge-freezer
with indoor electronics: provides a
modern door display**

- **XXL capacity:** extra space for your food when you need it.
- **LED lighting - with soft start, lasts for the lifetime of the appliance.**
- **VarioZone:** more flexibility due to variable-use glass shelves and drawers in the freezer compartment.
- **IceTwister:** easy to remove and fill - for lots of ice cubes.
- **Super Cooling:** cools new food placed inside faster, thus protecting already cooled food.

Energy Efficiency Class:	F
Average annual energy consumption in kilowatt hour per year (kWh/a):	413 kWh/annum
Sum of volume of frozen compartments:	208 l
Sum of volume of chill compartments:	372 l
Airborne acoustical noise emissions :	42 dB(A) re 1pW
Airborne acoustical noise emission class:	D
Built-in / Free-standing:	Free-standing
Door panel options:	Not possible
Height:	1787 mm
Width of the appliance:	908 mm
Depth:	707 mm
Net weight:	96.4 kg
Connection rating:	230 W
Fuse protection:	13 A
Door hinge:	left and right
Voltage:	220-240 V
Frequency:	50 Hz
Length electrical supply cord:	200.0 cm
Number of compressors:	1
Number of independent cooling systems:	1
Interior ventilator:	No
Reversible Door Hinge:	No
Number of Adjustable Shelves in fridge compartment:	0
Shelves for Bottles:	No
EAN code:	4242005185306
Brand:	Bosch
Product name / Commercial code:	KAN93VIFPG
Frost free system:	Fridge
Installation typology:	N/A
Included accessories:	1 x egg tray



**Series 4, American side by side,
178.7 x 90.8 cm, Brushed steel
anti-fingerprint
KAN93VIFPG**

- Climate Class: SN-T
- EU19_Fast freezer facility_D: yes
- Noise Level : 42 dB

**The NoFrost side-by-side fridge-freezer
with indoor electronics: provides a
modern door display**

Design features

- Easy Twist ice box
- Stainless Steel EasyClean doors and grey side panels
- aluminium Vertical door handle
- No Frost
- Automatic defrost fridge
- 1 compressor
- MultiAirflow system - improves circulation of air around the fridge
- Bright interior LED fridge light
- Removable magnetic door seals - easy to clean
- Optical and acoustic door open alarm

Freshness System

- VitaFresh plus: keeps food fresh for up to twice as long

Additional features

- 5 safety glass shelves in fridge compartment of which 0 are height adjustable
- 2 freezer drawers
- Left hinged, Right hinged door
- Height adjustable front feet

Functions

- SuperCool function
- SuperFreezing function with automatic deactivation

Key features - Fridge section

- 2 MultiBox drawers on rails - Transparent drawers with a corrugated bottom, ideal for storing fruits and vegetables.
- 3 removable door storage compartments.
- Door shelves in fridge door: 3 large and 2 small
- 3 x egg tray
- Bright interior LED fridge light

Key features - Freezer section

- Door trays in freezer door: 5
- To achieve the declared energy consumption, the distanceholders have to be used. As a result, the appliance depth increases by about 3.5 cm. The appliance used without the distance holder is fully functional, but has a slightly higher energy consumption.
- Dimensions: 178.7 cm H x 90.8 cm W x 70.7 cm D
- Electronic control for fridge and freezer with LED display

Performance and Consumption

- EU19_EEK_D: F
- Total Volume : 580 l
- Net Fridge Volume : 372 l
- Net Freezer Volume : 208 l
- Freezing capacity 24h : 12 kg
- Annual Energy Consumption: 413 kWh/a

**Series 4, American side by side,
178.7 x 90.8 cm, Brushed steel
anti-fingerprint
KAN93VIFPG**

Measurements in mm

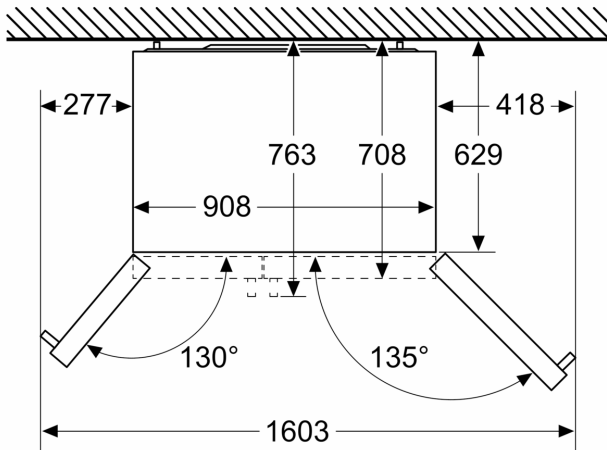

Measurements in mm

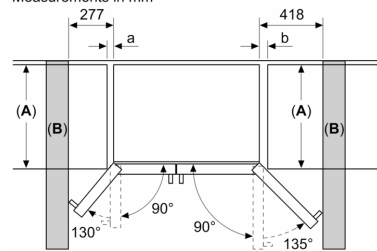

A	a	b
≤ 600	50	50
600 < A ≤ 650	50	50
650 < A ≤ 700	53	96
> 700	277	418

A: Kitchen cabinet or worktop depth

B: Wall
Drawers can be pulled out with door open to 90°

Drawers can be taken out with door completely opened

Measurements in mm

