

**Serie | 6, built-in microwave, 60 x 38
cm, White
HMT75M624B**

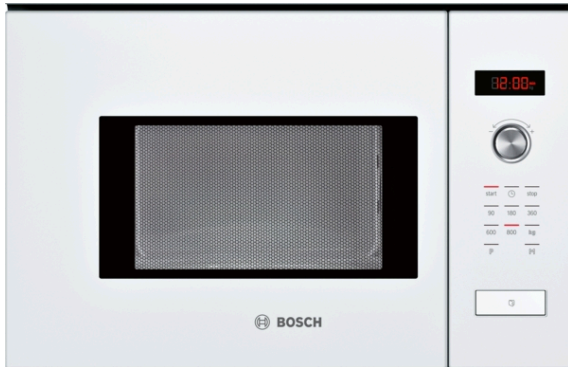

A great partner for the kitchen, the built-in compact microwave defrosts, heats and cooks helping you prepare food in the kitchen.

- **Red LED display control:** easy-to-use thanks to clear time display.
- **Pop-out controls:** Make the front of the oven easy to clean and give it a sleek look.
- **Red LCD display control:** easy-to-use thanks to direct access to additional functions, temperature recommendation and temperature indication.

Technical Data

Type of micro-wave oven : MW only
Type of control : Electronic
Color / Material Front : White
Cavity dimensions : 201.0 x 308.0 x 282.0 mm
Approval certificates : CE
Length electrical supply cord : 130 cm
Net weight : 16.405 kg
Gross weight : 18.1 kg
EAN code : 4242002788395
Maximum micro-wave power : 800 W
Connection Rating : 1270 W
Fuse protection : 10 A
Voltage : 230-240 V
Frequency : 50 Hz
Plug type : GB plug
Cavity dimensions : 201.0 x 308.0 x 282.0 mm



**Serie | 6, built-in microwave, 60 x 38 cm,
White
HMT75M624B**

A great partner for the kitchen, the built-in compact microwave defrosts, heats and cooks helping you prepare food in the kitchen.

Key Information

- Electronic control

Design

- 1 retractable control dial
- Push buttons
- Left hinged door
- Side opening door with viewing window

Features

- Electronic clock timer
- 1 interior light
- Stainless steel interior

Programmes/functions

- microwave
- 4 weight automatic defrost programmes
- 1 memory function

Performance/technical information

- Oven capacity: 20 litres
- Large 20 litre stainless steel interior
- Turntable distribution
- 255 mm turntable diameter
- 5 power levels: 800 W, 600 W, 360 W, 180 W, 90 W
- 5 microwave power levels
Maximum microwave power level: 800 W
- User-friendly electronics: extremely easy and comfortable operation
- For installation into a 60 cm wide wall unit, installation in tall housing

**Serie | 6, built-in microwave, 60 x 38 cm,
White
HMT75M624B**

Microwave,
corner installation

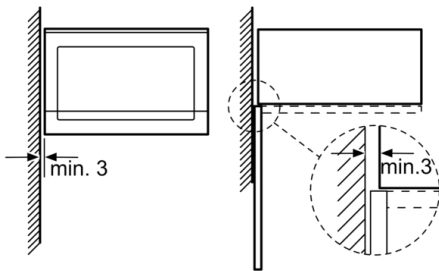

Measurements in mm

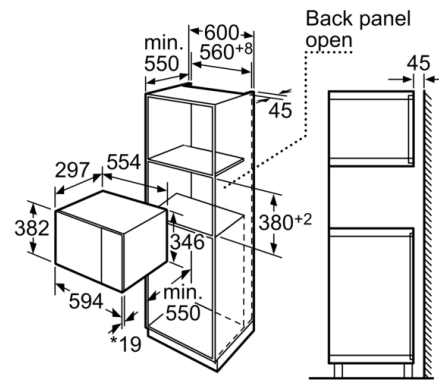

* 20 mm for metal fascias

measurements in mm

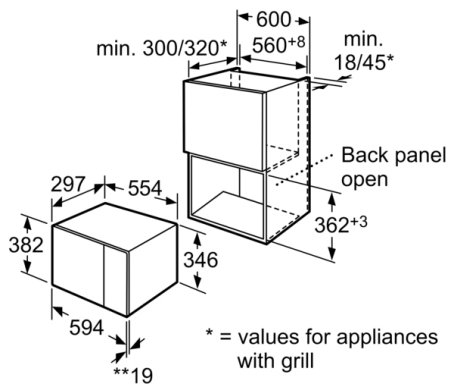

** 20 mm for metal fascias

measurements in mm