

**Series 8, heat pump tumble dryer, 9 kg
WTX87MH0SG**



The AutoClean Technology cleans the heatpump system automatically for multiple times, removing the lint and fluff thoroughly out of the system, ensuring the dryer to perform economically with optimal energy efficiency.

- **Auto Dry:** automatically dries to the exact degree of dryness you want.

Built-in / Free-standing:	Free-standing
Removable top:	No
Door opening:	Right
Color / Material body:	White
Length electrical supply cord:	145.0 cm
Dimensions:	842x598x613 mm
Net weight:	55.2 kg
Drum volume:	112 l
Fluorinated greenhouse gases:	No
Hermetically sealed equipment:	Yes
The quantity expressed in CO2 equivalent:	0.000 t
Connection Rating:	800 W
Fuse protection:	10 A
Voltage:	220-240 V
Frequency:	50 Hz
Drying process:	automatic
Capacity cotton - NEW (2010/30/EC):	9.0 kg
Energy efficiency rating (2010/30/EU):	A++
Power consumption in off-mode - NEW (2010/30/EC):	0.10 W
Power consumption in left-on mode - NEW (2010/30/EC):	0.10 W
Duration of the left-on mode - NEW (2012/30/EC):	30 min
Condensation efficiency class - NEW (2010/30/EC):	A

- WMZ20600 Wool in basket - accessory
- WTZ27400 Stacking kit with pull-out shelf
- WTZ27410 Stacking kit
- WTZPW20D Platform with pull-out, dryer, cubic



Series 8, heat pump tumble dryer, 9 kg WTX87MH0SG

The AutoClean Technology cleans the heatpump system automatically for multiple times, removing the lint and fluff thoroughly out of the system , ensuring the dryer to perform economically with optimal energy efficiency.

Technical Specification

- Capacity: 9 kg
- Dimensions (H x W x D): 84.2 cm x 59.8 cm x 61.3 cm

Programmes

- Cottons, Synthetics, Mix, Delicates, Wool Finish, Timed Porgram Warm, Smart Dry, AllergyPlus, Super Quick 40min, Towels, Sportswear, Down Wear, Duvet, Shirts/Blouses
- Touch control buttons: Low heat drying, Signal, Drying target, 24 h Delay end timer

Features

- Anti-Vibration Side Panels reduce vibrations and ensure greater stability during the washing and spinning process.
- Fine-adjustment of drying intensity to customise your preferred level of dryness
- Anti-crease cycle 60,min or 120min at the end of programme

Display Screen & Alerts

- LED Display for remaining time and 24 Hr end time delay, programme status indication, special functions
- Buzzer at the end of the wash programme

Safety

- Child-proof lock

Note: Above listed energy efficiency rating is according to EU directive 2010/30/EU

**Series 8, heat pump tumble dryer, 9
kg
WTX87MH0SG**

Measurements in mm

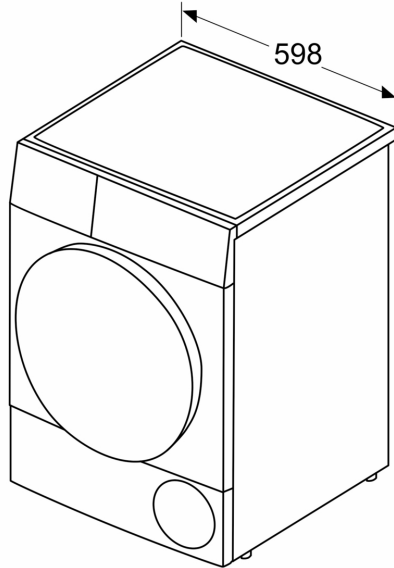

Measurements in mm

