

**Series 4, fully-integrated dishwasher,  
45 cm  
SPV4XM28E**



- SGZ0BI02 decorative strips stainless steel 81,5cm
- SGZ1010 inlet and outlet hose extention
- SGZ4CB00 Vario cutlery basket 45cm
- SMZ1051EU Mains cable with EU-Plug 5m
- SMZ5000 Dishwashing aid set
- SMZ5003 Retractable hinge f. high corpus dimens.
- SMZ5300 GlassSecure Tray

- **ExtraDry:** extra drying option for difficult-to-dry loads.
- **Flexibility in loading :** 3-level adjustment
- **Favourite function:** personalized function by just one touch even for downloaded programs.
- **AquaStop:** Bosch's warranty in case of water damage – throughout the lifetime of the appliance.\*

Energy Efficiency Class (Regulation (EU) 2017/1369):	..... F
Energy Consumption for 100 cycles Eco Programme (EU 2017/1369):	.....84 kWh
Maximum number of place settings (EU 2017/1369):	..... 10
The water consumption of the eco programme in liters per cycle (EU 2017/1369):	.....9.5 l
Programme duration (EU 2017/1369):	..... 3:40 h
Airborne acoustical noise emissions (EU 2017/1369):	.....46 dB(A) re 1 pW
Airborne acoustical noise emission class (EU 2017/1369):	..... C
Cleaning performance:	.....A
Water consumption:	.....9.5 l
Total annual energy consumption 220 days:	..... 183 kWh
Total annual water consumption 220 days:	..... 2090 l
Built-in / Free-standing:	..... Built-in
Removable top:	..... No
Door panel options:	..... Not possible
Height of removable worktop:	..... 0 mm
Height of the appliance:	..... 815 mm
Adjustable feet:	..... Yes - all from front
Maximum adjustability feet:	..... 60 mm
Adjustable plinth:	..... Both horizontal and vertical
Net weight:	.....28.8 kg
Gross weight:	..... 30.6 kg
Connection Rating:	..... 2400 W
Fuse protection:	.....10 A
Voltage:	..... 220-240 V
Frequency:	..... 50; 60 Hz
Length electrical supply cord:	..... 175.0 cm
Plug type:	..... Gardy plug w/ earthing
Length inlet hose:	..... 165 cm
Length outlet hose:	..... 205 cm
Hidden heating element:	..... Yes
Water protection system description:	..... Triple water protection 24h
Child safety devices:	..... No
Water softener:	.....Yes
Top basket type:	.....R3
Adjustable upper basket:	.....Rackmatic 3-stage
Bottom basket type:	..... R3
3rd Rack:	.....varioDrawer
Optional accessories: SGZ0BI02, SGZ1010, SGZ4CB00, SMZ1051EU, SMZ5000, SMZ5003, SMZ5300	
Included accessories 2:	..... Vapor barrier plate
Number of place settings:	..... 10
Dimensions of the product (HxWxD):	.....815 x 448 x 550 mm
Dimensions of the packed product (HxWxD):	..... 880 x 530 x 680 mm



## Series 4, fully-integrated dishwasher, 45 cm SPV4XMX28E

---

**Performance:**

- Capacity: 10 place settings
- Noise level: 46 dB(A) re 1 pW

**Programmes:**

- 6 programmes: Eco 50 °C, Auto Wash 45-65 °C, Intensive Wash 70 °C, 1 Hour Wash 65 °C, Silence 50 °C, Favourite
- Pre-Rinse/ Favourite

**Function:**

- 4 special options: Home Connect, ExtraDry, IntensiveZone, SpeedPerfect+
- Machine Care Programme

**Design:**

- Stainless steel cavity
- varioDrawer
- Rackmatic height-adjustable top basket (3 stage)
- DosageAssist
- duoPower double spray arm
- 3-fold corrugated filter
- Electronic touch button

**Display:**

- InfoLight red
- Remaining programme time indicator (min)
- Preset timer: 1-24 hours

**Advanced Technology:**

- Heat exchanger.
- EcoSilence Drive motor for heat and drain pump
- Detergent Automation
- AquaStop anti-flood system

**Technical Information:**

- Dimensions of the product (HxWxD): 81.5 x 44.8 x 55cm

Note1 : Above listed energy efficiency rating is according to EU directive 2010/30/EU

**Series 4, fully-integrated dishwasher,  
45 cm  
SPV4XM28E**

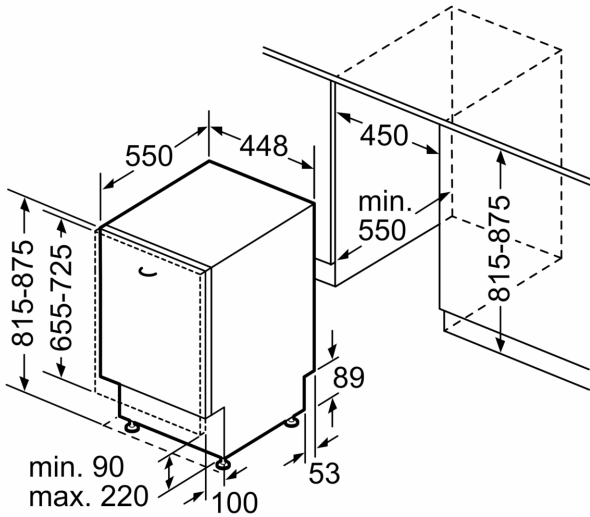

measurements in mm

measurements in mm

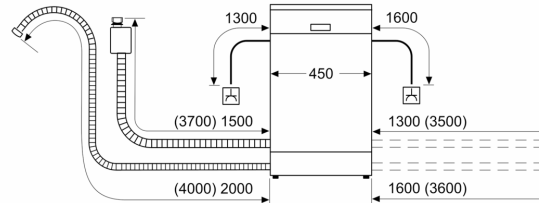

⌚ socket  
( ) values with extension kit