

**Serie | 6, built-under freezer, 82 x 59.8 cm
GUD15A50GB**



The freezer with 3 transparent freezer drawers and SuperFreezing: freezes new items placed inside even faster.

- An audible alarm system signals the door is open
- **SuperFreezing:** protection for pre-frozen food.
- Installs Completely Flush

Technical data

Product category :	Upright freezer
Built-in / Free-standing :	Built-in
Frost free system :	No
Climate class :	SN-ST
Door panel options :	Possible but accessory
Width of the appliance :	598
Depth of the product :	548
Dimensions of the packed product (HxWxD) (mm) :	890 x 620 x 670
Warning signal / malfunction :	visual and audible
Defrost process :	manual
Cover door installation system :	Fixed-mounted
Number of drawers/baskets (Stck) :	3
Number of freezing flaps (Stck) :	0
Lockable door :	No
Thermometer freeze section :	Analog
Light :	No
Length electrical supply cord (cm) :	230
Door hinge :	Right reversible
Net weight (kg) :	36.172
Gross weight (kg) :	38.3
Multi-Flow Air Tower :	No
Number of compressors :	1
Number of independent cooling systems :	1
Economy setting :	No
Fast freezing switch :	No
Door bin adjustability - Freezer :	No
Tilt-out door bins in freezer :	No
Door bin adjustability - Freezer :	No
Reversible Door Hinge :	Yes
Connection Rating (W) :	90
Current (A) :	13
Frequency (Hz) :	50
Approval certificates :	CE, VDE
Main colour of product :	N/A
Door panel options :	Possible but accessory
Installation typology :	Built-under
Noise level (dB(A) re 1 pW) :	38
Energy Star Qualified :	No
Approval certificates :	CE, VDE
Plug type :	GB plug
Required cutout/niche size for installation (in) :	x x
Dimensions of the packed product (in) :	35.03 x 26.37 x 24.40
Net weight (lbs) :	80.000
Gross weight (lbs) :	85.000



Serie | 6, built-under freezer, 82 x 59.8 cm GUD15A50GB

The freezer with 3 transparent freezer drawers and SuperFreezing: freezes new items placed inside even faster.

Features

- Energy efficiency class: A+
- Net freezer capacity: 98 litres
- 3 transparent freezer drawers
- Door right hinged, reversible
- Flush-folding hinge
- Ventilation in plinth, no cut-out in the worksurface necessary
- Automatic switch off
- Freezing calendar
- Freezer malfunction warning signal: Optical Warning System by Temperatur increase, Acoustic Warning System

Technical information

- Freezing capacity: 12 kg in 24 hours
- Storage time in power failure: 23 H
- Noise level: 38 dB
- Connected load: 90 W

Appliance Dimension

- Dimensions: 82 cm (H) x 59.8 cm (W) x 54.8 cm (D)

**Serie | 6, built-under freezer, 82 x 59.8 cm
GUD15A50GB**

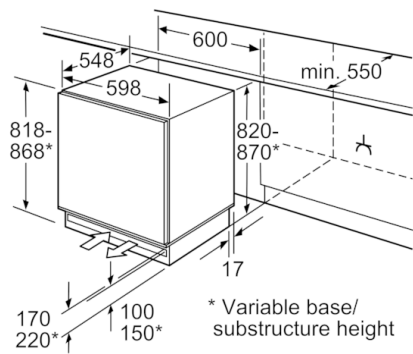

Space for electrical connection next to the appliance on the left or right-hand side.
Ventilation space in the base.

measurements in mm