

**Series 4, telescopic cooker hood, 90 cm, Silver metallic DFS097A51B**



- DWZ2IT114 Clean Air Standard recirculation kit
- DSZ4920 Installation kit for 90cm wide wall unit
- DSZ4961 Lowering frame
- DWZ2IT1B4 Clean Air Standard odor filter (repl.)

**Telescopic cooker hood: barely visible integrated in the wall unit, this ensures a clear kitchen design.**

- **EcoSilence Drive:** the powerful, energy-saving drive for hoods.
- **Glacier Aesthetics with Practical Design**

Typology: ..... Pull-out  
 Length electrical supply cord: ..... 175 cm  
 Required niche size for installation (HxWxD): ... 385mm x 524.0mm x 290mm mm  
 Net weight: ..... 12.4 kg  
 Control panel: ..... Electronic  
 Number of speed settings: ..... 3-stages + intensive setting  
 Maximum output air extraction: ..... 397 m<sup>3</sup>/h  
 Boost position output recirculating: ..... 628 m<sup>3</sup>/h  
 Maximum output recirculating air: ..... 358 m<sup>3</sup>/h  
 Boost position air extraction: ..... 729 m<sup>3</sup>/h  
 Number of lights: ..... 3  
 Noise level: ..... 53 dB(A) re 1pW  
 Diameter of air outlet: ..... 120 / 150 mm  
 Grease filter material: ..... Washable stainless steel  
 Odour filter: ..... No  
 Operating Mode: ..... Exhaust or re-circulate air operation  
 Type of lamps used: ..... LED  
 Total power of the lamps: ..... 6 W  
 Grease filter type: ..... Kasette  
 Clean filter reminders: ..... No  
 Connection Rating: ..... 146 W  
 Fuse protection: ..... 10 A  
 Voltage: ..... 220-240 V  
 Frequency: ..... 50; 60 Hz  
 Plug type: ..... GB plug  
 Installation typology: ..... Built-in  
 Material body: ..... zinc plated  
 Plug type: ..... GB plug  
 Dimensions of the product, with chimney (if exists) (in): ..... x x  
 Dimensions of the packed product: ..... 15.74 x 37.00 x 19.29  
 Net weight: ..... 27.000 lbs  
 Gross weight: ..... 34.000 lbs  
 Motor location: ..... Integrated motor in hood body  
 No-return airflow flap: ..... Yes  
 Length electrical supply cord: ..... 175 cm  
 Dimensions of the product, with chimney (if exists): .... 400x900x290 mm  
 Dimensions of the packed product (HxWxD): ..... 400x940x490 mm  
 Net weight: ..... 12.4 kg  
 Gross weight: ..... 15.3 kg



**Series 4, telescopic cooker hood, 90 cm, Silver metallic DFS097A51B**

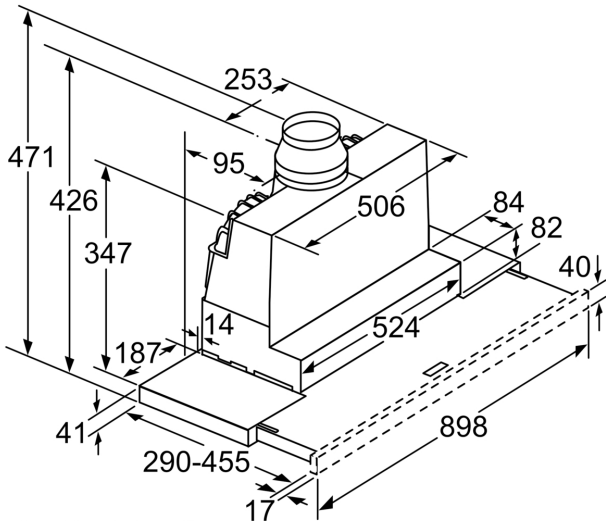

Depth of the filter drawer can be adjusted by up to 29 mm

measurements in mm

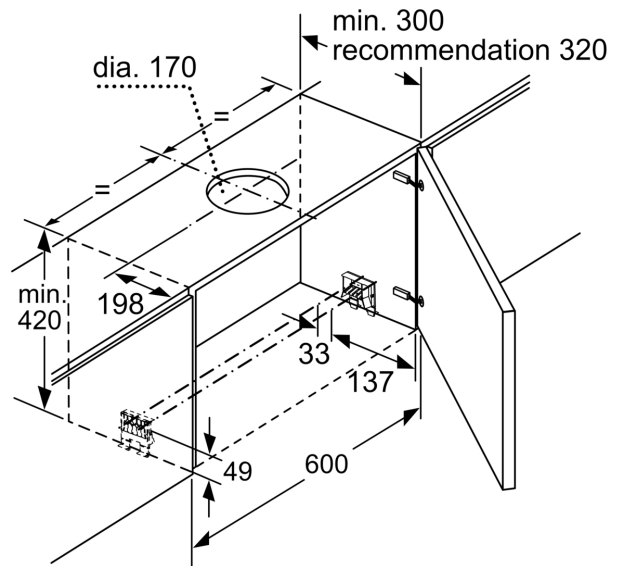

measurements in mm

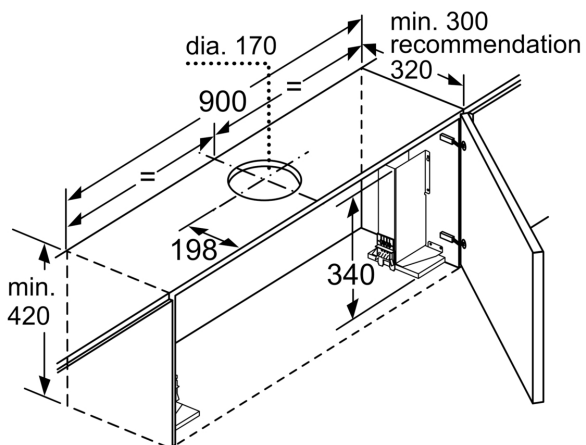

When installing the 90 cm telescopic hood in a 90 cm wide wall-hanging cupboard, a mounting kit is required. The two mounting brackets are screwed onto the left and right of the kitchen unit. Installation in accordance with template.

measurements in mm

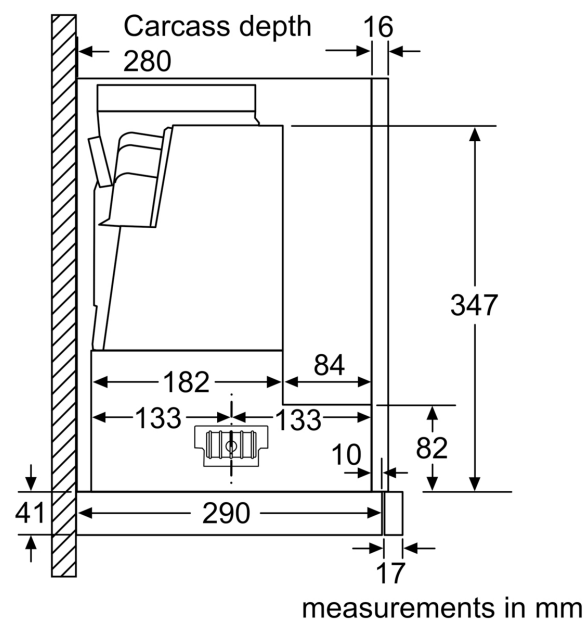

measurements in mm

