

**Serie | 8, downdraft hood, 90 cm,
clear glass black printed
DDA097G59B**



- **Intensive speed setting:** removes strong kitchen odours especially quickly and effectively.

Technical data

Typology :	Traditional
Approval certificates :	CE, G-Mark, VDE
Length electrical supply cord (cm) :	150
Required niche size for installation (HxWxD) :	652mm x 812.0mm x 113mm
Height of product, without chimney (mm) :	651
Net weight (kg) :	35.061
Type of control :	Electronic
Number of speed settings :	4-stage + 1 intensive
Maximum output air extraction (m ³ /h) :	530
Boost position output recirculating (m ³ /h) :	680.0
Boost position air extraction (m ³ /h) :	710
Number of lights :	1
Noise level (dB(A) re 1 pW) :	65
Diameter of air outlet (mm) :	150
Grease filter material :	Washable aluminium
Odour filter :	No
Operating Mode :	Convertible
Delay Shut off modes :	15
Optional accessories :	DHZ5376
Grease filter type :	Kassette
Connection Rating (W) :	285
Current (A) :	10
Voltage (V) :	220-240
Frequency (Hz) :	50
Plug type :	GB plug
Installation typology :	Built-in
Material body :	Stainless steel
Approval certificates :	CE, G-Mark, VDE
Plug type :	GB plug
Dimensions of the product, with chimney (if exists) (in) :	/ x x
Dimensions of the packed product (in) :	24.80 x 33.46 x 44.88
Net weight (lbs) :	77.000
Gross weight (lbs) :	102.000
Motor location :	Integrated motor in hood body
Discharge direction :	downward
No-return airflow flap :	No
Length electrical supply cord (cm) :	150
Dimensions of the product, with chimney (if exists) (mm) :	651 - 1052 x 912.0 x 352.0
Dimensions of the packed product (HxWxD) (mm) :	630 x 850 x 1140
Net weight (kg) :	35.061
Gross weight (kg) :	46.2



**Serie | 8, downdraft hood, 90 cm, clear glass
black printed
DDA097G59B**

Design:

Design:

Feature:

Operating mode / operation

Power:

Supplied Accessories:

Optional Accessory:

Technical Information:

Technical information:

- Appliance colour: brushed steel
- Suitable for ducted or re-circulated extraction
- Charcoal filter
- Top
- TouchControl
- 4 speeds plus intensive operation
- Saturation indicator for metal grease filter
- dualTurbo Drive cooker hood
- Twin channel high performance fan motor
- Rim ventilation
- Supplied with 2 dishwasher safe metal grease filters
- Extraction rate according to EN61591: 710 m³/h
- Total connected load: 285 W
- Dimensions recirculating (HxWxD): 651 - 1052 x 912 x 352 mm
- Dimensions exhaust air (HxWxD): 651 - 1052 x 912 x 352 mm

**Serie | 8, downdraft hood, 90 cm, clear glass
black printed
DDA097G59B**

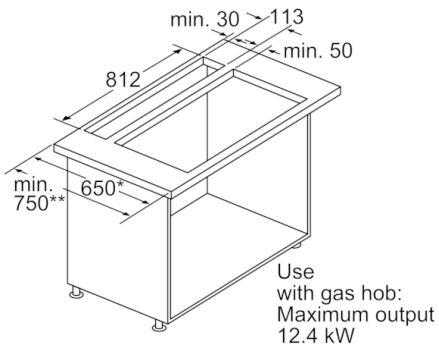

- * 650 mm depth only in combination with slim hobs.
 - ** min. 750 mm for hobs with 500 mm cut-out depth.
- measurements in mm

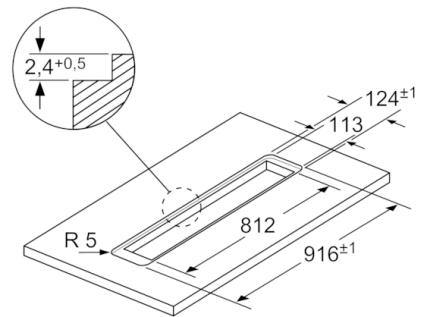
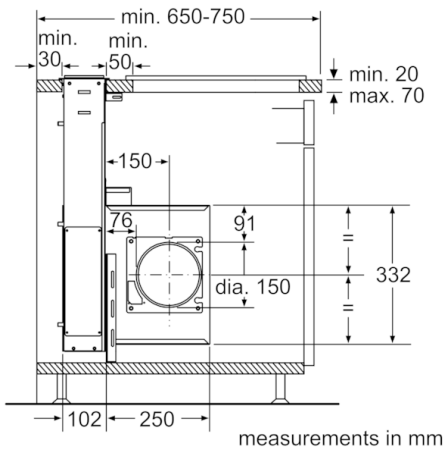
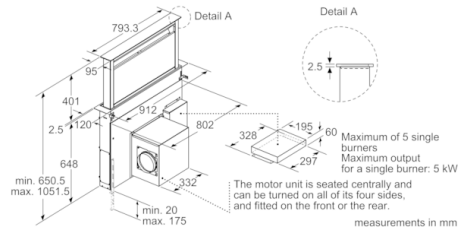

For flush installation
in stone and granite work surfaces

measurements in mm