

**Series 6, Condenser tumble dryer, 7 kg
WTE84106GB**



B



Optional accessories

- WTZ10290 Cover plate
- WTZ1110 Condenser drainage kit
- WTZ11300 Stacking kit with pull-out shelf
- WTZ11310 Stacking kit

Classixx : rely on laundry care specially developed with allergy sufferers in mind.

- **Auto Dry:** automatically senses when your preferred level is reached.
- **Anti-Vibration Design:** extremely stable vibration protection ensures a smooth operation.
- **Fast drying:** dries a full load considerably fast.
- **Sensitive Drying System:** for gentle drying without creases.
- **SensitiveDrying System:** the unique drum structure protects and delivers a drying performance without creases.

Technical Data

Built-in / Free-standing: Freestanding
 Removable top: Yes
 Door hinge: Right
 Length electrical supply cord: 145.0 cm
 Height of removable worktop: 23 mm
 Dimensions: 842 x 598 x 626 mm
 Net weight: 38.0 kg
 EAN code: 4242002764603
 Connection rating: 2800 W
 Fuse protection: 13 A
 Voltage: 220-240 V
 Frequency: 50 Hz
 Loading capacity: 7.0 kg
 Energy efficiency rating: B
 Energy consumption electric dryer, full load - NEW (2010/30/EC) 4.20 kWh
 Standard cotton programme time at full load: 124 min
 Energy consumption electric dryer, partial load - NEW (2010/30/EC): 2.30 kWh
 Standard cotton programme time at partial load: 76 min
 Weighted annual energy consumption, electric dryer - NEW (2010/30/EC): 504.0 kWh/annum
 Weighted programme time: 97 min
 Average condensation efficiency full load (%): 89 %
 Average condensation efficiency partial load (%): 89 %
 Weighted condensation efficiency (%): 89 %



Series 6, Condenser tumble dryer, 7 kg WTE84106GB

Classixx : rely on laundry care specially developed with allergy sufferers in mind.

Performance

- Energy Efficiency Class: B at a range of energy efficiency classes from A+++ to D
- Capacity: 7 kg
- Energy consumption 504.0 kWh per year, based on 160 drying cycles of the standard cotton programme at full and partial load, and the consumption of the low-power modes. Actual energy consumption per cycle will depend on how the appliance is used
- Energy consumption of the standard cotton programme at full load 4.2 kWh and energy consumption of the standard cotton programme at half load 2.3 kWh
- The programme Cotton cupboard dryused at full and partial load is the standard drying programme to which the information in the label and the fiche relates, this programme is suitable for drying normal wet cotton laundry and is the most efficient programme in terms of energy consumption for cotton.
- Programme time of the standard cotton programme at full load 124 min and programme time of the standard cotton programme at partial load 76 min.
- Weighted programme time of the standard cotton programme at full and partial load: 97 min.
- Condensation efficiency class B on a scale from G (least efficient) to A (most efficient).
- Average condensation efficiency of the standard cotton programme at full load 89 % and average condensation efficiency of the standard cotton programme at partial load 89 %.
- Weighted condensation efficiency for the standard cotton programme at full and partial load: 89 %.
- Power consumption in off-mode 0.1 W and in left-on mode 1 W
- Noise level: 66 dB (A) re 1 pW

Programmes/functions

- Fully electronic control dial for sensor programmes and timed programmes
- Special programmes: Sportswear, Timed Programme 20 minutes warm, Super Quick 40
- Touch control buttons: Start/Stop, Low heat

Key features

- Sensitive drying: large galvanised drum and revolution drying system
- AntiVibration design: for greater stability and quietness

Additional features

- LED programme progress indicator and warning for fluff filter
- Anti crease cycle 120 min at the end of the programme
- Metal door catch

Technical Information

- Dimensions (H X W X D): 84.2 x 59.8 x 63.9 cm
- Can be built-under
- Round solid door,, white

**Series 6, Condenser tumble dryer, 7
kg
WTE84106GB**

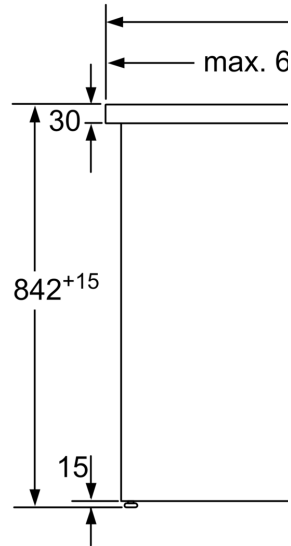
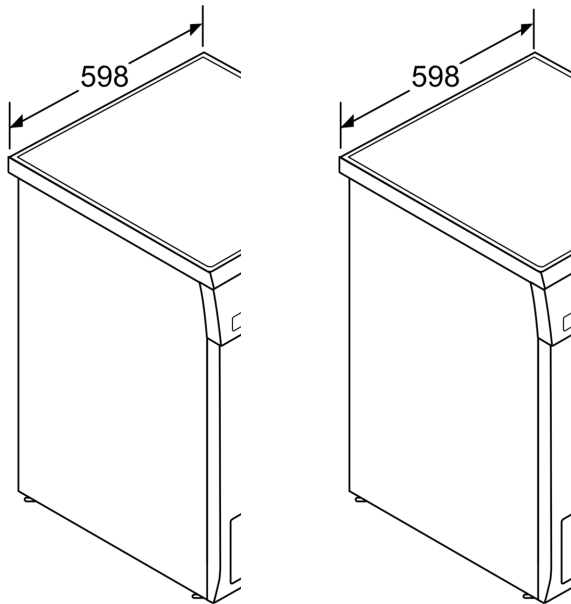

Measurements in mm

