

## Condenser tumble dryer, 9 kg WTB86590GB



### Optional accessories

WMZ20500	Platform with pull-out
WTZ11400	Stacking kit with pull-out shelf
WTZ20410	Stacking kit

## The Maxx with large 9 kg drum: for soft and even drying of large capacities.

**B**

- **Auto Dry:** automatically senses when your preferred level is reached.
- **Anti Vibration Design:** extremely stable and especially quiet thanks to special vibration protection.
- **Fast drying:** dries a full load considerably fast.
- **Sensitive Drying System:** for gentle drying without creases.
- **Allergy Plus:** designed with allergies and sensitive skin in mind.

### Technical Data

Built-in / Free-standing: .....	Freestanding
Removable top: .....	No
Door hinge: .....	Right
Length electrical supply cord: .....	145.0 cm
Height of removable worktop: .....	0 mm
Dimensions: .....	842 x 598 x 599 mm
Net weight: .....	40.4 kg
EAN code: .....	4242002808482
Connection rating: .....	2600 W
Fuse protection: .....	13 A
Voltage: .....	220-240 V
Frequency: .....	50 Hz
Loading capacity: .....	9.0 kg
Energy efficiency rating: .....	B
Energy consumption electric dryer, full load - NEW (2010/30/EC):	5.23 kWh
Standard cotton programme time at full load: .....	150 min
Energy consumption electric dryer, partial load - NEW (2010/30/EC):	2.78 kWh
Standard cotton programme time at partial load: .....	80 min
Weighted annual energy consumption, electric dryer - NEW (2010/30/EC): .....	616.0 kWh/annum
Weighted programme time: .....	110 min
Average condensation efficiency full load (%): .....	88 %
Average condensation efficiency partial load (%): .....	88 %
Weighted condensation efficiency (%): .....	88 %



## Condenser tumble dryer, 9 kg WTB86590GB

### The Maxx with large 9 kg drum: for soft and even drying of large capacities.

---

#### Performance

- Energy Efficiency Class: B at a range of energy efficiency classes from A+++ to D
- Capacity: 9 kg
- Energy consumption 616.0 kWh per year, based on 160 drying cycles of the standard cotton programme at full and partial load, and the consumption of the low-power modes. Actual energy consumption per cycle will depend on how the appliance is used
- Energy consumption of the standard cotton programme at full load 5.23 kWh and energy consumption of the standard cotton programme at half load 2.78 kWh
- The programme Cotton cupboard dryused at full and partial load is the standard drying programme to which the information in the label and the fiche relates, this programme is suitable for drying normal wet cotton laundry and is the most efficient programme in terms of energy consumption for cotton.
- Power consumption in off-mode 0.1 W and in left-on mode 0.5 W
- Duration of left-on mode: 0 min
- Weighted programme time of the standard cotton programme at full and partial load: 110 min.
- Programme time of the standard cotton programme at full load 150 min and programme time of the standard cotton programme at partial load 80 min.
- Condensation efficiency class B on a scale from G (least efficient) to A (most efficient).
- Weighted condensation efficiency for the standard cotton programme at full and partial load: 88 %.
- Average condensation efficiency of the standard cotton programme at full load 88 % and average condensation efficiency of the standard cotton programme at partial load 88 %.
- Noise level: 64 dB (A) re 1 pW

#### Programmes/functions

- Fully electronic control dial for sensor drying, including timed and special programmes
- Special programmes: Mixed Load, Wool drying in basket, Timed programme warm, Allergy +, Sportswear, Delicates, Down, Super Quick 40, Shirts 15
- Buttons: start/pause, Low heat, Buzzer, Reduced ironing, Drying length, fine-tuning for drying level, 24 h, end Time Delay

#### Key features

- Sensitive drying: large stainless steel drum with textile care and revolution drying system
- AntiVibration design: for greater stability and quietness

#### Additional features

- LED Display for remaining time and 24 hours time delay, programme status indication, special functions
- Anti crease cycle 120 min at the end of the programme
- Wool drying basket
- Container for condensed water
- Drum interior light
- Child lock
- Buzzer to indicate the end of cycle
- Metal door catch

#### Technical Information

- Dimensions (H X W X D): 84.2 x 59.8 x 65.2 cm
- slide-under installation
- Glass door, silver-white



**Condenser tumble dryer, 9 kg  
WTB86590GB**

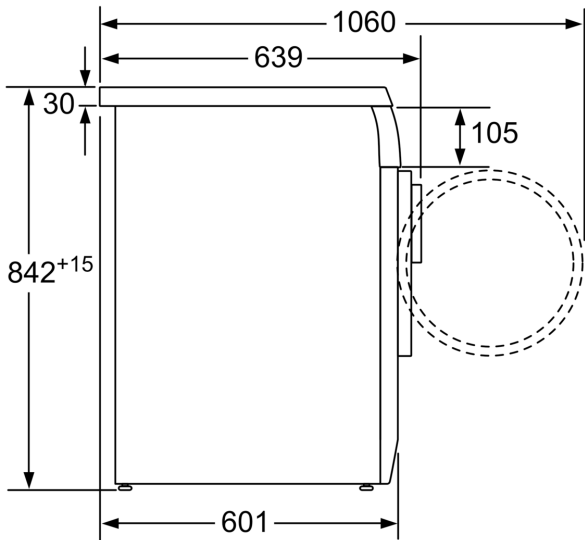

measurements in mm

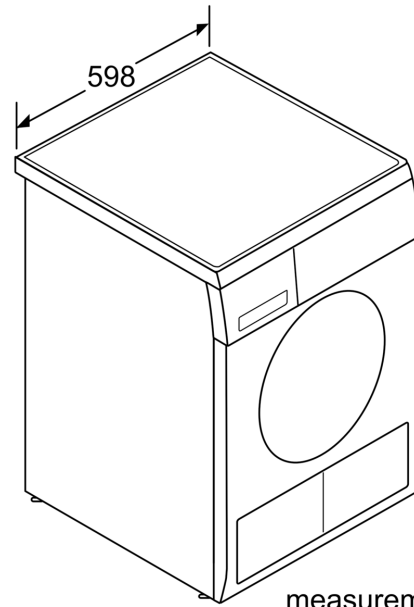

measurements in mm