

Series 6, Heat pump tumble dryer, 9 kg, Cast iron grey WQH246DRGB



A highly advanced heatpump dryer with Smart Dry powered by Home Connect. Maximise your energy savings with A+++ -10%* and the Self Cleaning condenser. Protect your garments with Auto Dry.

- **Our energy champion A+++ -10%:** 10% more efficient than energy efficiency class A+++
- **Self-Cleaning Condenser:** Automatic fluff-cleaning condenser.
- **Speed Perfect:** Dry your clothes even faster.
- **Bed Linen programme with reversing drum:** No more tangling.
- **Auto Dry:** Automatically senses when your load is dried.

Technical Data

Removable top:	No
Built-in / Free-standing:	Freestanding
Door hinge:	Right
Length electrical supply cord:	180 cm
Dimensions:	842x598x613 mm
Net weight:	52.1 kg
Fluorinated greenhouse gases:	R290
Hermetically sealed equipment:	Yes
EAN code:	4242005522217
Connection rating:	800 W
Fuse protection:	10 A
Voltage:	220-240 V
Frequency:	50 Hz
Loading capacity:	9.0 kg
Energy efficiency rating:	A+++
Energy consumption electric dryer, full load - NEW (2010/30/EC):	1.44 kWh
Energy consumption electric dryer, partial load - NEW (2010/30/EC):	0.76 kWh
Condensation efficiency class - NEW (2010/30/EC):	A
Average condensation efficiency full load (%):	90 %
Average condensation efficiency partial load (%):	91 %

Optional accessories

- WTZ27500 Stacking kit with pull-out shelf
- WTZ27510 Stacking kit



Series 6, Heat pump tumble dryer, 9 kg, Cast iron grey WQH246DRGB

A highly advanced heatpump dryer with Smart Dry powered by Home Connect. Maximise your energy savings with A+++ -10%* and the Self Cleaning condenser. Protect your garments with Auto Dry.

Performance

- Energy Efficiency Class¹: A+++
- 10% more efficient than energy efficiency class A+++***
- Energy²: 171 kWh
- Capacity: 1 - 9 kg
- Programme time³: 265 min
- Noise level: 60 dB (A) re 1 pW
- Condensation efficiency class⁴: A
- Condensation efficiency⁵: 91 %

Programmes/functions

- Standard programmes: cotton, easy care
- Bed Linen Program: reduces tangling of big items thanks to reversible drum
- Programmes via app: Wool in the basket, Woollens finish, Time program cold
- Special programmes: Cottons, Shirts/blouses, Cotton Eco, Delicates, Towels, Mixed Load, Super Quick 40, Sportswear, Easy-Care, Timed programme warm

Key features

- Home Connect: Remote Monitoring and Control, Energy Management, Remote Diagnostics, SmartDry, further programmes via download. Always keep your appliance up to date via firmware update.
- SmartDry: Perfect drying programme based on last washing cycle
- Speed Perfect: Reduce drying time in selected programmes
- Half Load option: optimises drying for smaller loads
- Anti crease cycle 120 min at the end of the programme
- Touch control buttons: end Time Delay, Reduced ironing, Child lock 3 sec., Power button, Remote Start, Low heat, Start / Reload / Pause, speedPerfect, Drying aim, 24 h end Time Delay

Additional features

- SC1R
- Elegant and ergonomically inclined control panel for easy use
- Large LED display for remaining time and 24 hours time delay, programme progress indication and special functions
- Load recommendation
- Fully electronic control dial for sensor programmes and timed programmes
- Jog dial
- Sensitive drying: large stainless steel drum with textile care and revolution drying system
- AntiVibration design: for greater stability and quietness
- No
- Drum interior light
- Container for condensed water

- Child lock
- Buzzer to indicate the end of cycle
- Usage meter: counts completed programmes
- NewValue door with cover glass, Alu-Look, black grey
- Metal door catch

Technical Information

- slide-under installation
- Dimensions (H x W): 842 mm x 598 mm
- Appliance depth: 613 mm
- Appliance depth incl. door: 648 mm
- Appliance depth with open door: 1096 mm
- Heat pump technology with climate friendly cooling agent

¹ At a range of energy efficiency classes from A+++ to D

² Energy consumption kWh per year, based on 160 drying cycles of the standard cotton programme at full and partial load, and the consumption of the low power modes

³ Programme time of the standard cotton programme at full load

⁴ On a condensation efficiency class scale from A to G

⁵ Weighted condensation efficiency for the standard cotton programme at full and partial load

*** 10% more efficient (171 kWh/year) than the limit value (194kWh/year) of the energy efficiency class A+++ in category 9kg according to delegated EU-Regulation 392/2012

**Series 6, Heat pump tumble dryer, 9
kg, Cast iron grey
WQH246DRGB**

Measurements in mm

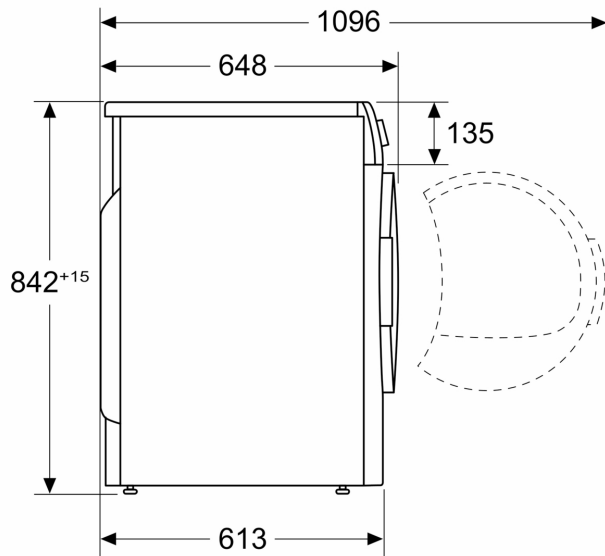

Measurements in mm

