

**Serie | 8, Washing machine, front loader, 10 kg, 1600 rpm
WAX32GH1GB**



The ultimate washing machine with Home Connect, AntiStain Plus System and 4D Wash System with Intensive Plus provides spotless results with every load in the smartest way.

- **AntiStain:** detects and removes the 16 most common stains.
- **Home Connect:** home appliances with smart connectivity for an easier everyday life.
- **EcoSilence Drive™:** extremely energy-efficient and quiet in operation with a 10-year warranty.
- **AllergyPlus:** specially developed for the needs of allergy sufferers and sensitive skin.
- **SpeedPerfect:** perfectly clean in up to 65% less time.

Technical Data

Construction type :	Free-standing
Height of removable worktop (mm) :	850
Dimensions of the product (mm) :	848 x 598 x 590
Net weight (kg) :	81.903
Connection rating (W) :	2300
Current (A) :	10
Voltage (V) :	220-240
Frequency (Hz) :	50
Approval certificates :	CE, VDE
Length of electrical supply cord (cm) :	210
Washing performance class :	A
Door hinge :	Left
Wheels :	No
EAN code :	4242005168439
Capacity cotton (kg) - NEW (2010/30/EC) :	10.0
Energy efficiency rating :	A+++
Energy consumption annual (kWh/annum) - NEW (2010/30/EC) :	167.00
:	0.12
:	0.50
Water consumption annual (l/annum) - NEW (2010/30/EC) :	12100
Spin drying performance class :	A
Maximum spin speed (rpm) - NEW (2010/30/EC) :	1600
Average washing time cotton 40C (partial load) - NEW (2010/30/EC) :	180
Average washing time cotton 60C (full load) (min) - NEW (2010/30/EC) :	285
Average washing time cotton 60C (partial load) - NEW (2010/30/EC) :	255
:	20
Noise level washing (dB(A) re 1 pW) :	47
Noise level spinning (dB(A) re 1 pW) :	72
Installation type :	Free-standing

Optional accessories

WMZ2200 : Floor securing component

WMZ2381 : Extension for cold water inlet /Aquastop



Serie | 8, Washing machine, front loader, 10 kg, 1600 rpm WAX32GH1GB

The ultimate washing machine with Home Connect, AntiStain Plus System and 4D Wash System with Intensive Plus provides spotless results with every load in the smartest way.

Performance

- Energy Efficiency Class: A+++
- Capacity: 10 kg
- Maximum spin speed: 1600 rpm**
- A spin class
- Energy consumption :Weighted p.a. E-Consump. EU: 167 kWh kWh per year, based on 220 standard washing cycles
- -30% more economical (167kWh/year) than the standard value (239 kWh/year) of energy efficiency class A+++ in category 10 kg according to the EU-order 1061/2010
- Energy consumption: standard 60 °C cotton programme 0.98 kWh full load and 0.55 kWh partial load and 40 °C cotton programme 0.61 kWh partial load
- Cottons 60 Eco and Cottons 40 Eco are the standard washing programmes to which the information in the label relates. These programmes are suitable to clean normally soiled cotton laundry and are the most efficient programmes in terms of combined energy and water consumption.
- Weighted power consumption off-mode / left-on mode: 0.12 W / 0.5 W
- Water consumption 12100 litres per year, based on 220 standard washing cycles
- Programme time:60 °C cotton programme 285 min at full load 255 min at partial load and 40 °C cotton programme 180 min partial load
- Left-on Mode Duration: 20 min
- Drum volume: 70 litres
- Noise level washing : 47dB (A) re 1pW: Noise level spinning:72dB (A) re 1 pW

Programmes/functions

- TFT display: Clear text and high resolution for easy use with display of programme indication, temperature selection, spin speed, remaining time, 24 hour time delay and consumption indication
- Touch control buttons: Prog 3 sec., On/off, Ready in, stain selection, Intensive Plus, options, Remote Start, start/pause

with reload function, Temperature selection, SpeedPerfect, Spin speed reduction/Rinse Hold

- Standard programmes: cottons, easy care, delicates, wool hand wash
- Special programmes: Allergy +, Drain, Drum clean with reminder, Towels, Shirts, Quiet Wash, Dark Wash, Spin, Mixed Load, Sportswear, Single Rinse, Duvet, Super Quick 15/30
- options: 1 - 3 additional rinse cycles, Easy iron, Soaking, AntiStain +, Intensive Plus, Night Wash, SpeedPerfect, Rinse hold, Prewash, Water plus
- Safeguard monitoring system adjusts load distribution and programme settings to protect clothes

Key features

- 4D Wash System: highly efficient water and detergent fabric penetration for spotless results.
- Home Connect: Remote Monitoring and Control, Energy Management
- AutoStain Removal System with 16 stain options
- Automatic load detection for precise detection of loaded laundry to adjust automatically the amount of water is needed in every wash.
- Reload function: Flexibility in adding laundry items into the drum, even after the wash cycle has started.
- ActiveWater: water management system
- EcoSilence drive with 10 year warranty
- AntiVibration Design - for more stability and quietness
- EcoBar Plus function: five possible levels of energy and water consumption

Additional features

- WaveDrum: gentle and efficient washing
- Consump indicator energy+water, Load scale and detergent dosage recommendation, AutoStain Removal System
- Flow-through sensor for optimum water use
- Drum clean with reminder function
- Metal Control dial with integrated On / Off mode
- Drum interior light
- Sound insulation by additional noise reduction material
- Child lock
- Multiple Water Protection
- Foam detection system
- Overdosage indication
- Detergent dispensing: easy clean
- Divider for Liquid Detergent
- Multi-tone acoustic signal to indicate end of cycle

Technical Information

- Slide-under installation
- Large chrome, white door with 180° opening and 32cm porthole opening
- Dimensions (H x W): 84.8 cm x 59.8 cm
- Appliance depth: 59.0 cm
- Appliance depth incl. door: 63.2 cm
- Appliance depth with open door: 108.5 cm

*** Values are rounded.*

**Serie | 8, Washing machine, front loader, 10
kg, 1600 rpm
WAX32GH1GB**

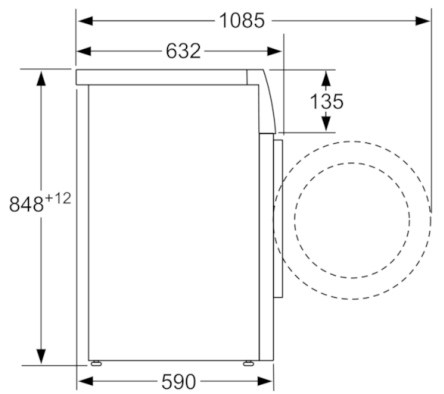

measurements in mm